

App Inventor for Android



CAVE Education



App Inventor 中文學 習網/檔案庫/2.pdf



時間	Day 2
主題	App Inventor基礎
8:10~8:30	報到
8:40~9:30	MapTour 預設名勝地點 連接Google map
9:30~10:00	QR Code 讀取器
10:15~11:50	No Text While Driving 自動簡訊回覆 資料庫 TinyDB
中餐午休	
13:00~14:20	LEGO MINDSTORMS 介紹以及建構技巧 NXT info 擷取機器人主機資訊 藍牙通訊原理
14:30~16:00	Show sensor value 藍牙連線 將感應器值回傳至手機 Button control 繪製按鈕 前進/後退 左轉/右轉



MapTour

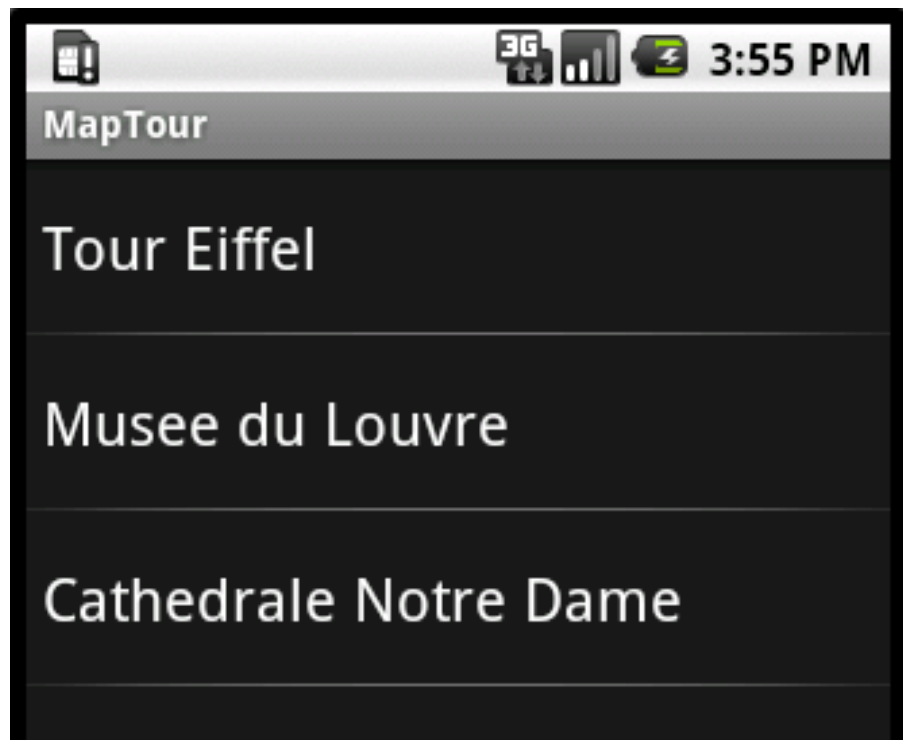

- ListPicker
- ActivityStarter



Designer



Palette\Basic\Image

Palette\Basic\ListPicker

Palette\Other stuff \ActivityStarter



在Image元件picture的地方放上parismap的圖片，請注意本圖片並無實際作用。

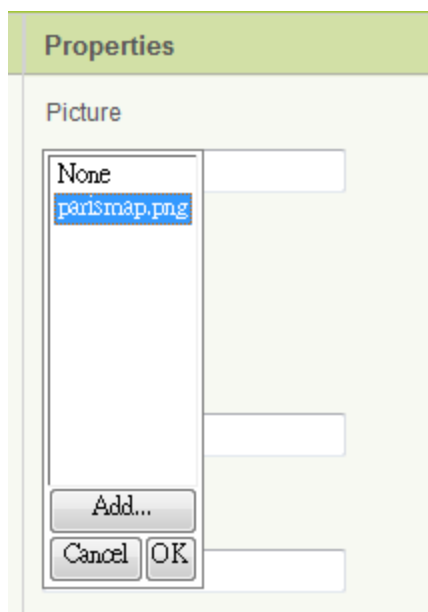

在ActivityStarter 元件加入下列設定，代表要
呼叫Google Map

Property	
Action	android.intent.action.VIEW
ActivityPackage	com.google.android.apps.maps
ActivityClass	com.google.android.maps.Map Activity

http://mapki.com/wiki/Google_Map_Parameters





MapTour

Save

Save As

Checkpoint

Blocks Editor is open

Package for Phone

Palette

Viewer

Components

Properties

Basic

- Button
- Canvas
- CheckBox
- Clock
- Image
- Label
- ListPicker
- PasswordTextBox
- TextBox
- TinyDB

Media

Animation

Social

Sensors

Screen Arrangement

Other stuff

Not ready for prime time

Old stuff



Non-visible components



- Screen1
 - Image1
 - ListPicker1
 - ActivityStarter1

Rename...

Delete...

Media

parismap.png

Add...

Image

Picture

parismap.png...

Visible



Width

Automatic...

Height

Automatic...



Block Editor



新增變數

(1) Built-in\Definition\def variable

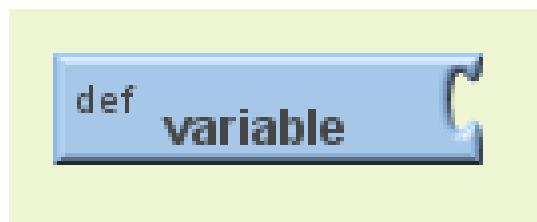

(2) 將variable改名為destinations



建立列表

(1) Built-in\Lists\make a list

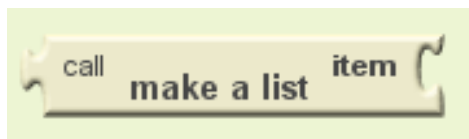

(2) Built-in\Texts\text

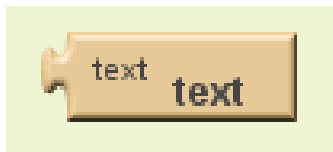

(3) 拉出三個text分別打入Tour Eiffel、Musee du Louvre、Cathedrale Notre Dame等地名



將destinations、make a list和三個text連接起來

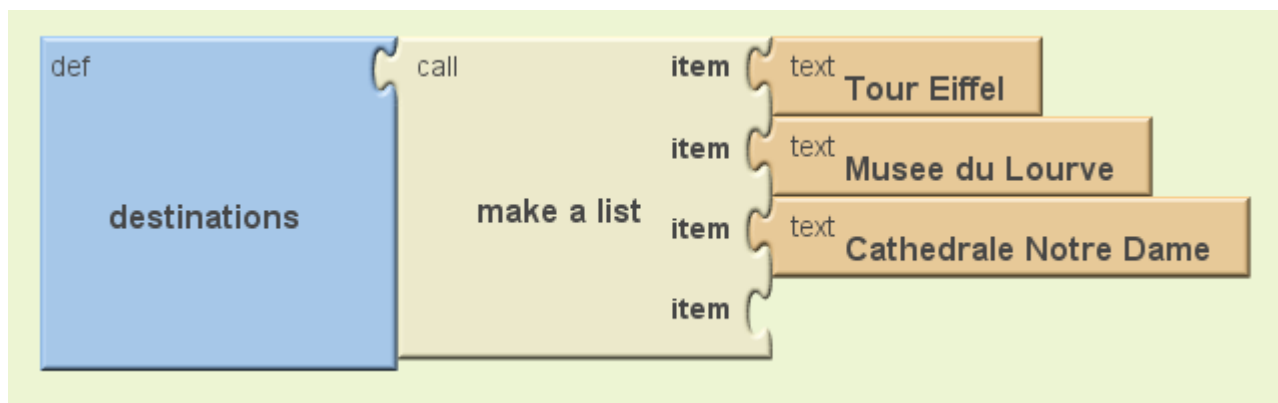

設定螢幕初始狀態

(1) My Blocks\Screen 1\ Screen 1.Initialize

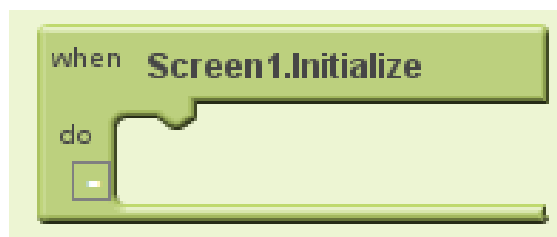

(2) My Blocks>ListPicker 1\ ListPicker1.Elements

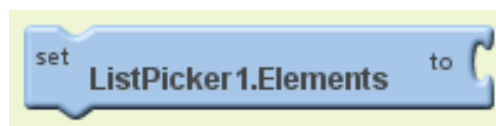

(3)My Blocks\My Definitions\global destinations

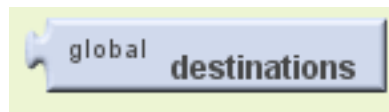

當程式開始時，將ListPicker會去抓 destination的內容

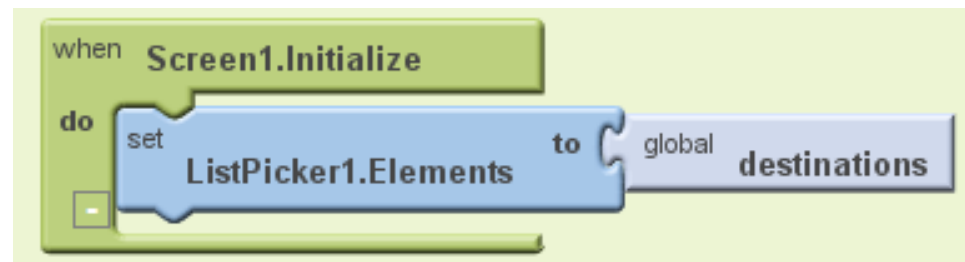

設定搜尋目標與啟動地圖

(1) My Blocks\ListPicker 1\ListPicker 1.AfterPicking



(2)My Blocks\ ActivityStarter 1\ActivityStarter 1.DataUri

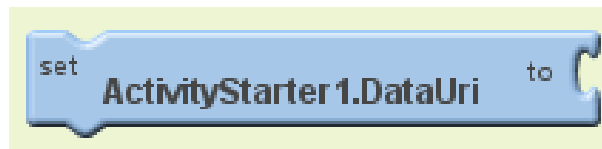

(3)Built-in\Texts\make text

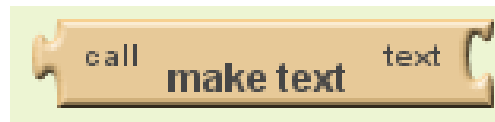

(4) Built-in\Texts\text

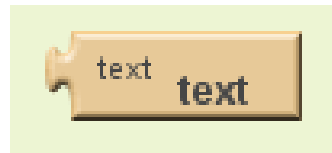

(5) 將text內容改為geo:0,0?q=

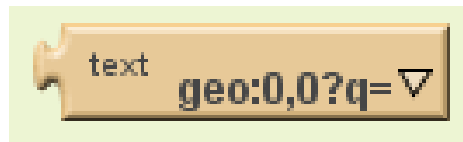

(6)My Blocks\ListPicker 1\ListPicker 1.Selection



(7)My Blocks\ActivityStarter 1\ActivityStarter 1.StartActivity



選擇ListPicker某元件之後即透過ActivityStarter來處理。意即將地圖資訊透過網路送出到Google Map後顯示。

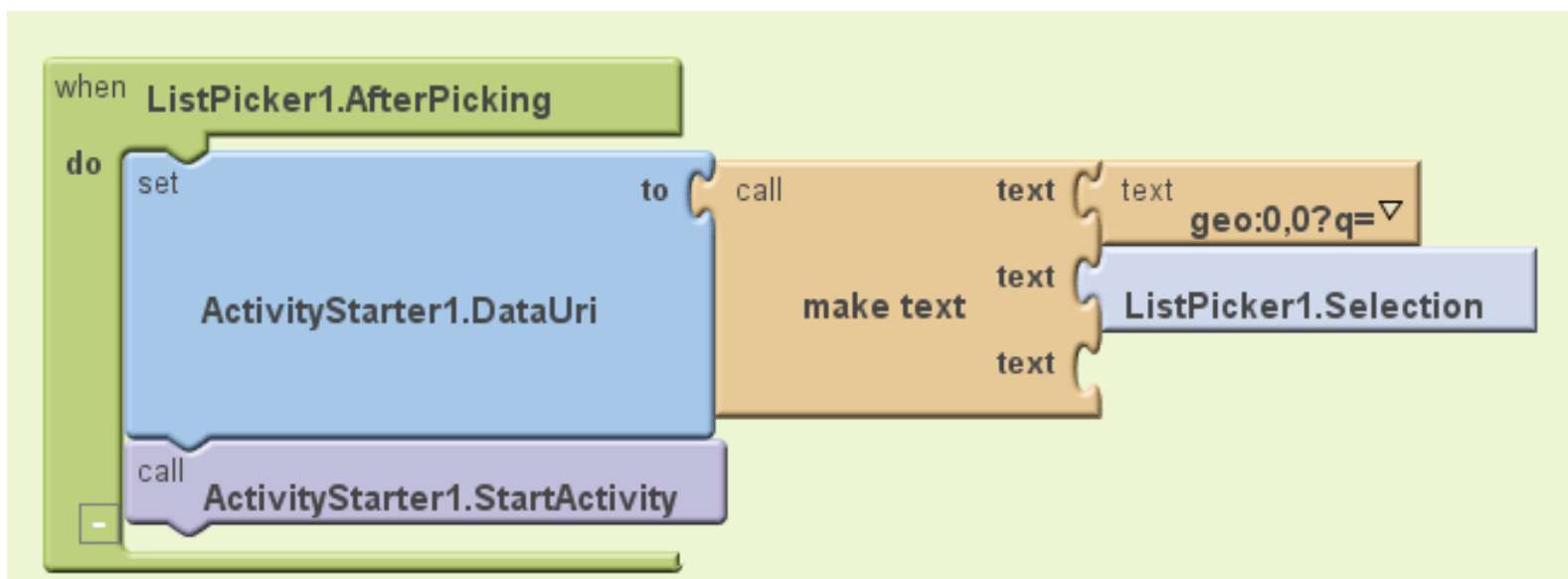

程式完成

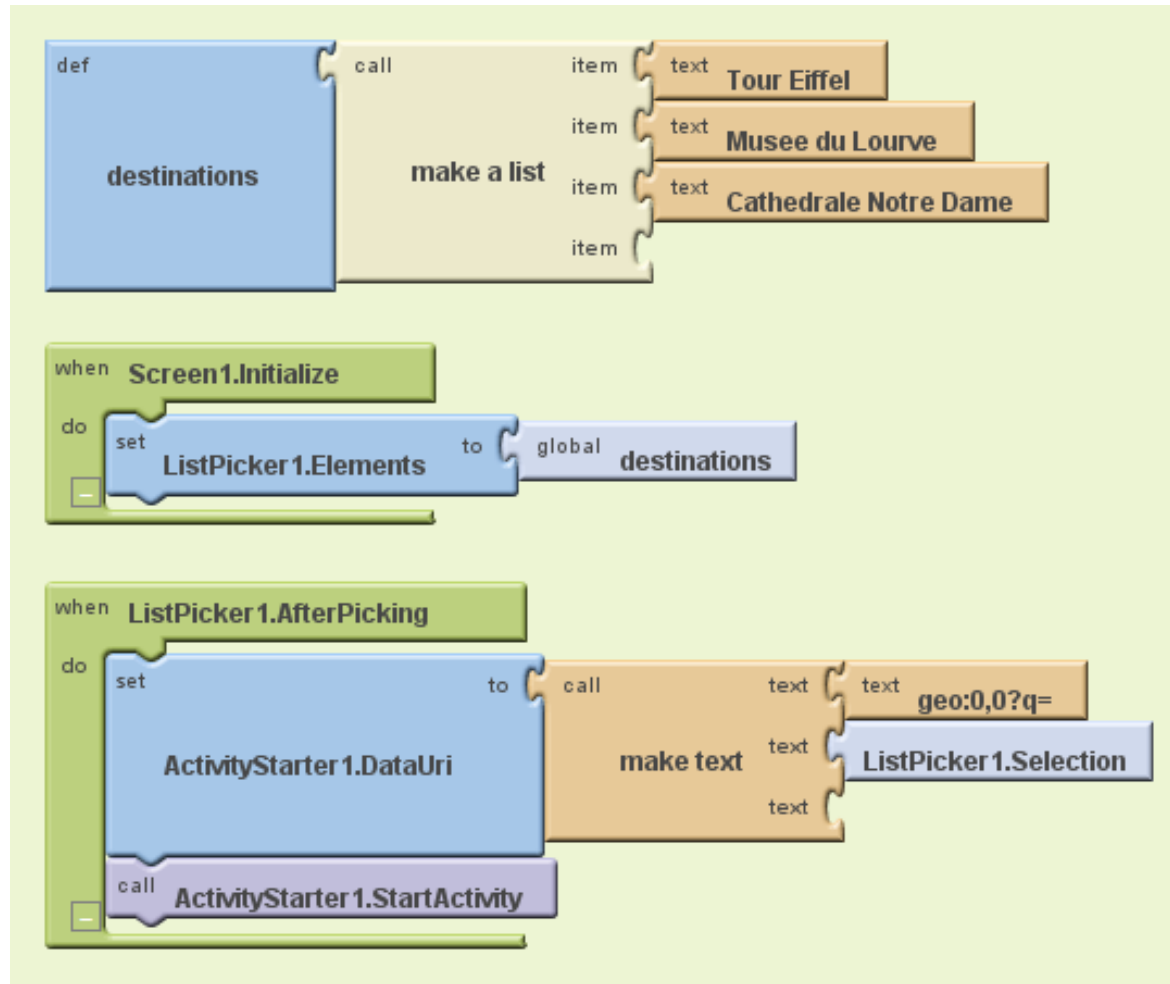

延伸練習

1. 在手機列表中加入「Taipei 101」的選項並順利顯示
2. 直接輸入經緯度後顯示位置(可透過Google Map查詢某地點之經緯度)



QR Code Scanner

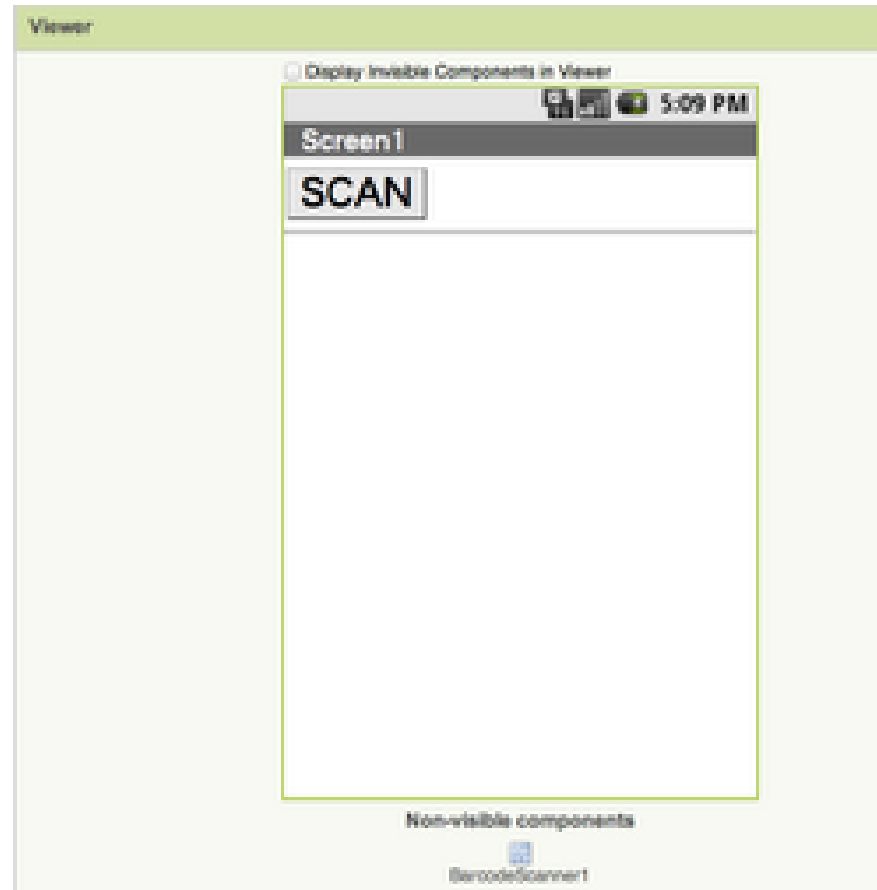

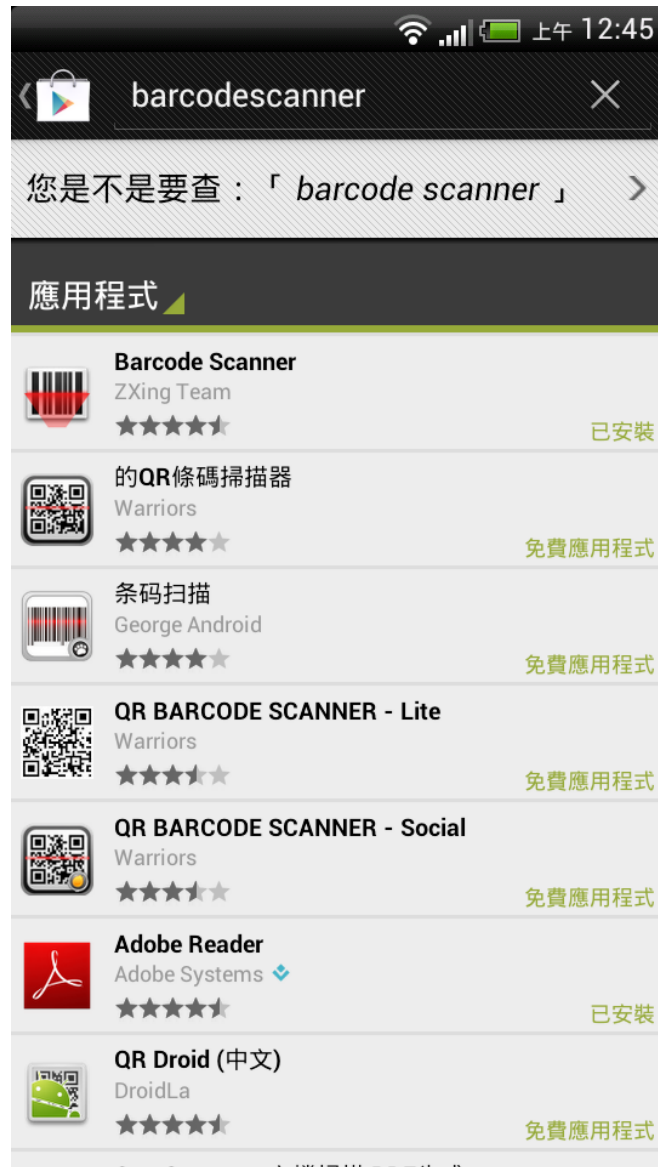

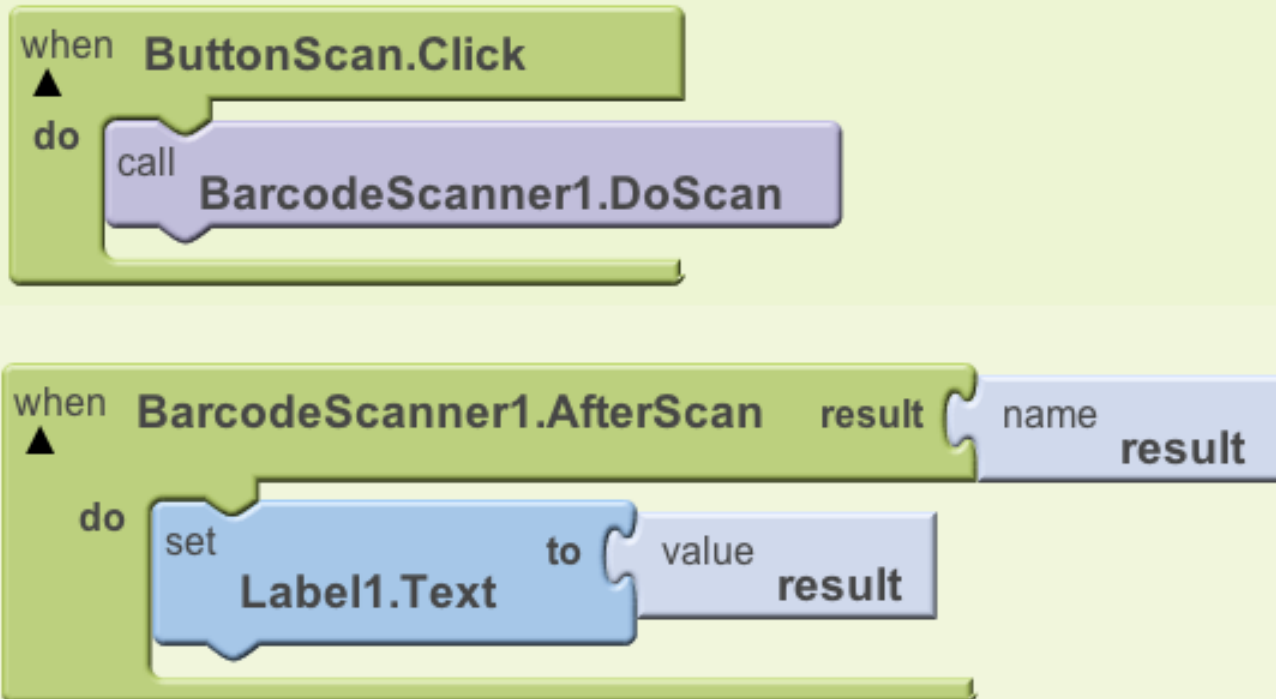



GOT A QR CODE READER?
DOWNLOAD KAYWA READER



URL Text Phone Number SMS

http://tw.yahoo.com/

Generate FREE

Generate SAFE

SAVE THIS CODE TO ADD IT TO YOUR BLOG OR YOUR DOCUMENTS. You can also use the code's [permalink](#), or copy-paste the following HTML code:

```

```

<http://qrcode.kaywa.com/>



No Text While Driving



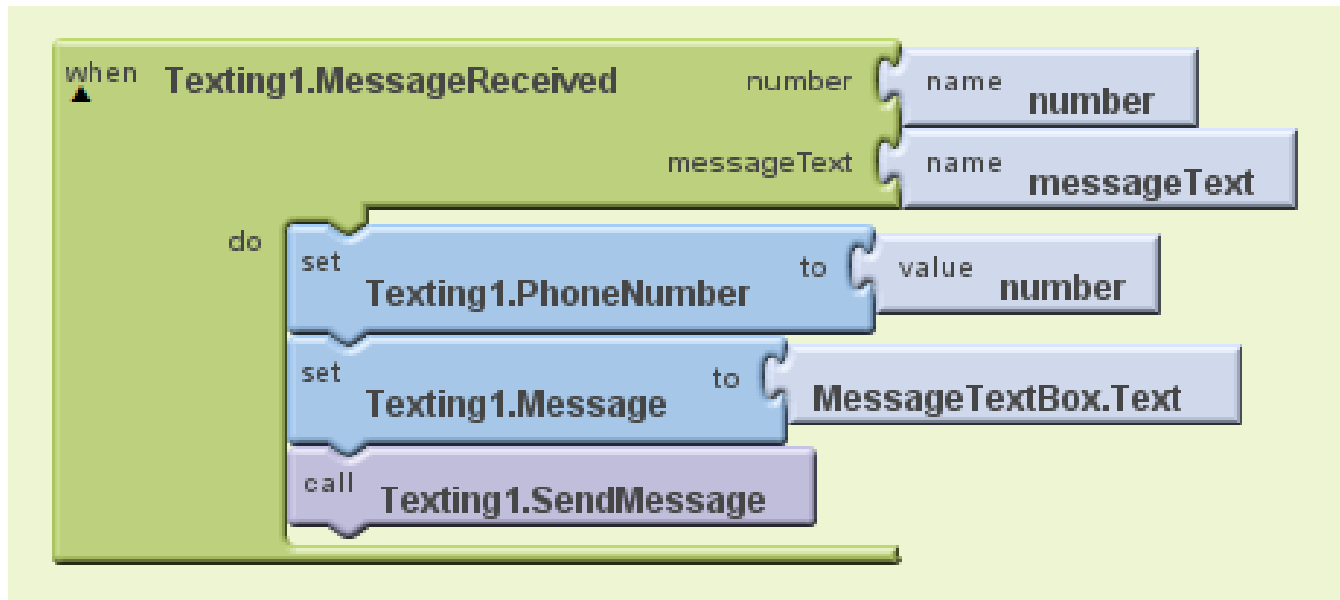

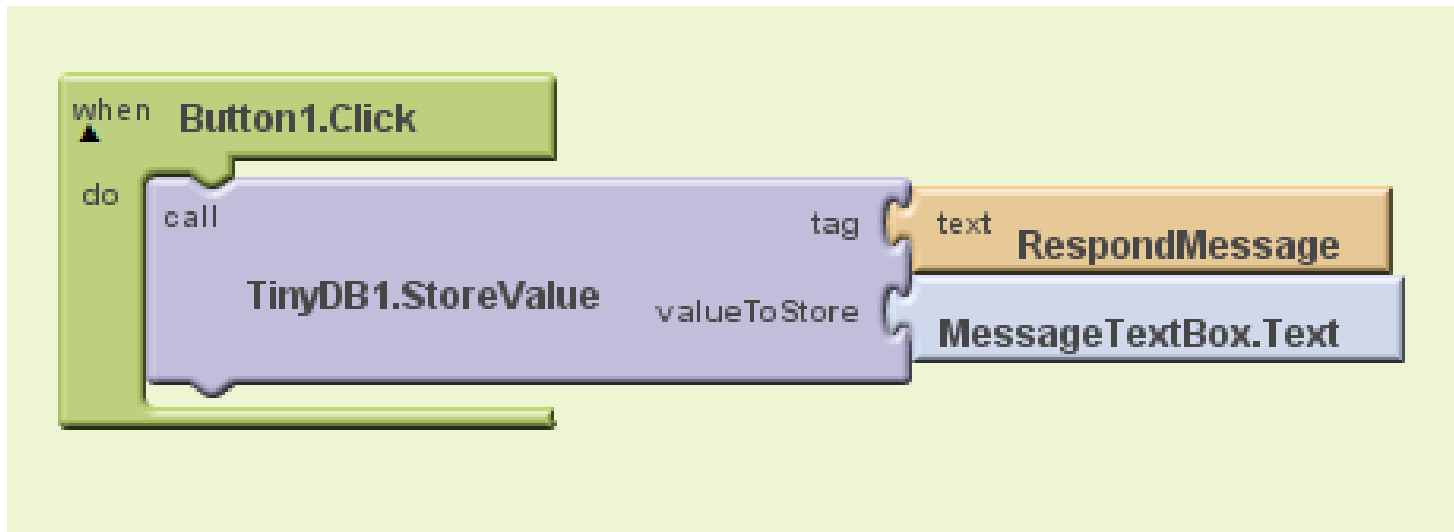

```
def response as text text ▾
```

```
when Screen1.Initialize  
do  
  set global response to call TinyDB1.GetValue tag text RespondMessage  
  if test call length text global response > number 0  
  then-do  
    set MessageTextBox.Text to global response
```



延伸練習

1. 在自動回覆的訊息中加入位置資訊



App Inventor with LEGO NXT robot

CAVE Education



- Lego Beyond Toys !



Lego Mindstorms 簡介

電子零件介紹



■ 馬達介紹

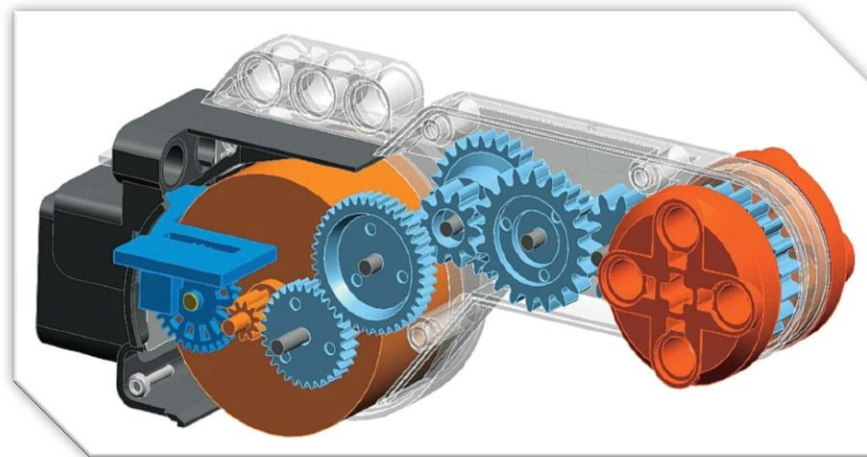
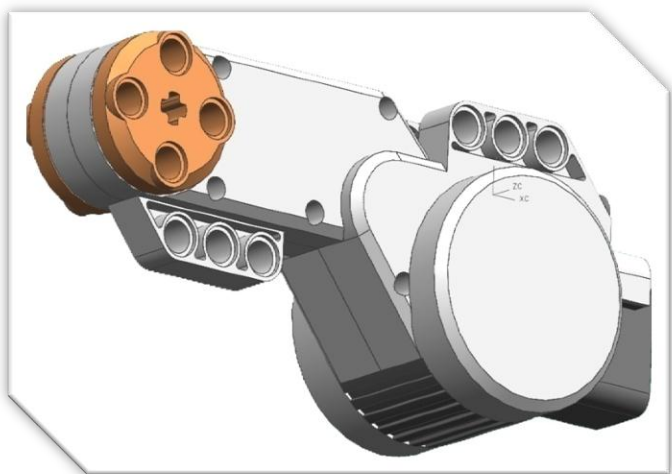

特色：

- 高扭力
- 內建角度感應器



各式樂高馬達簡介

9 V supply	 2838	 2986	 71427	 43362	 5292
Rotation speed (rotations per minute)	4100 rpm	35 rpm	360 rpm	340 rpm	1300 rpm
No-load current	35 mA	6 mA	3.5 mA	9 mA	160 mA
9 V supply	 47154	 NXT	 PF Medium	 PF XL	 9V Train
Rotation speed (rotations per minute)	460 rpm	170 rpm	405 rpm	220 rpm	2000rpm
No-load current	31 mA	60 mA	65 mA	80 mA	90mA

☐ <http://www.philohome.com>



■ 感應器介紹

觸碰感應器

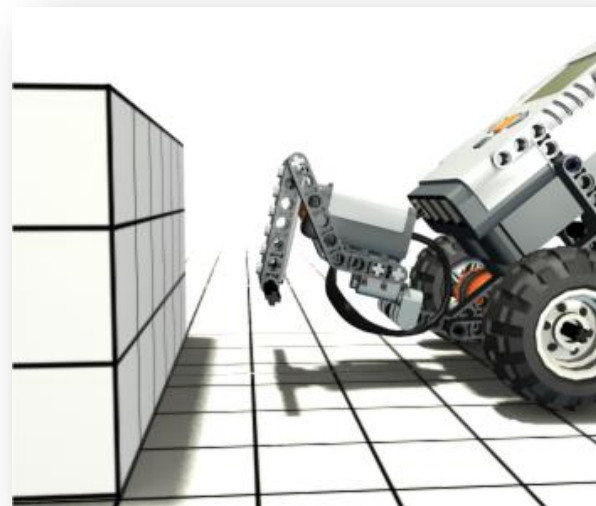

光感應器

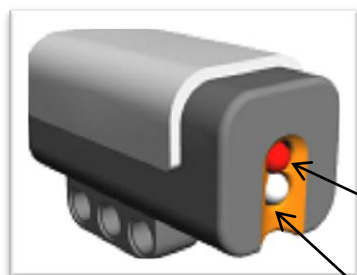

phototransistor

LED



偵測顏色表面的光強度



聲音感應器



▣ 最高可偵測約90分貝



超音波感應器



▣ 最遠可偵測約255cm



他牌感應器

 **Hitechnic**



Color Sensor



NXT EOPD



NXT IRSeeker



NXT Compass Sensor

<http://www.hitechnic.com/>

 **Mindsensor** mindsensors.com



Vision Subsystem v3 for NXT



Line Sensor Array



Pneumatic Pressure Sensor

<http://www.mindsensors.com/>



2. 零件的建構

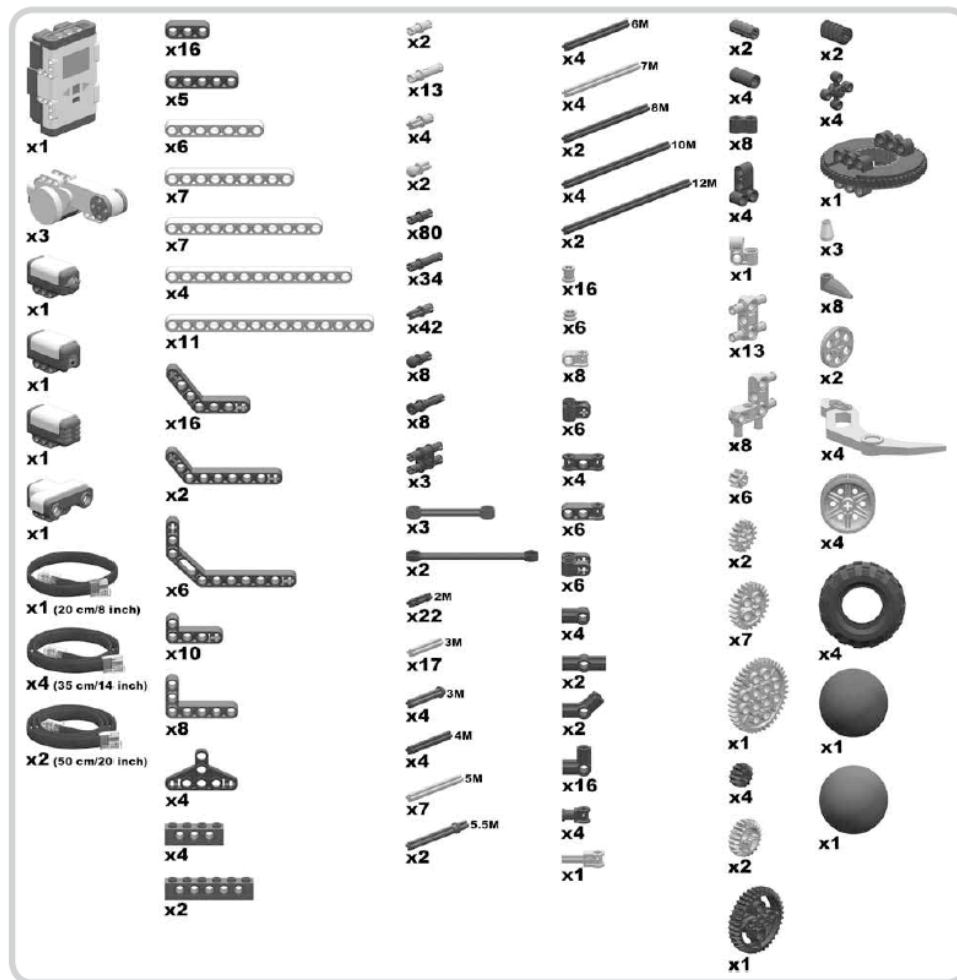

- 連桿
- 連接器
- 齒輪
- 其他



- 連桿 (Beams)

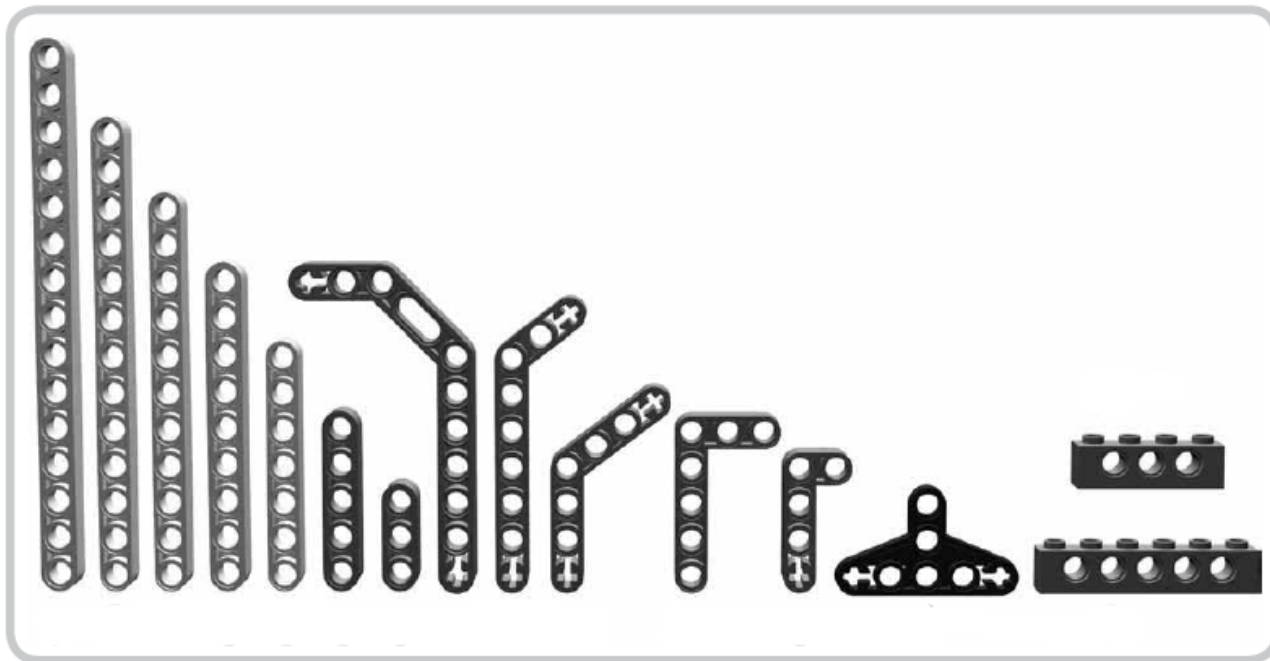

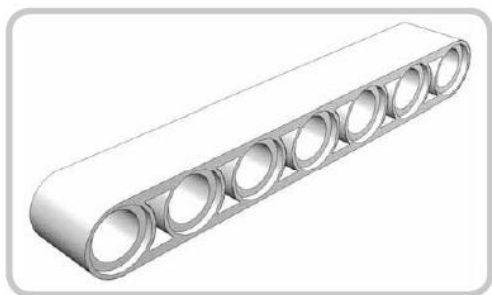

直連桿

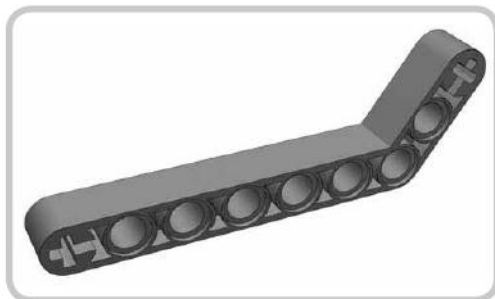

角度連桿



半連桿



樂高單位

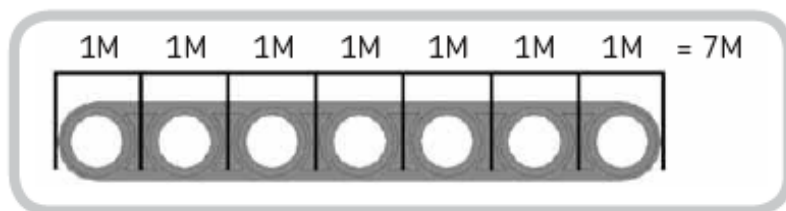
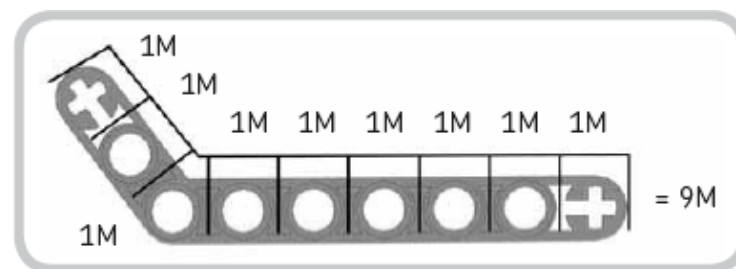
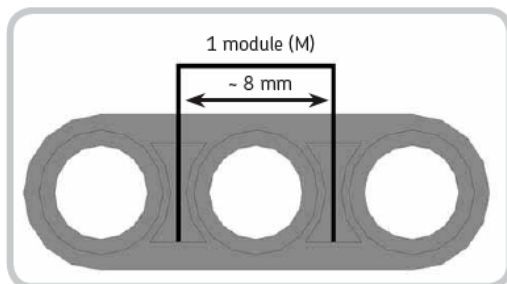

- 連接器(Connectors)

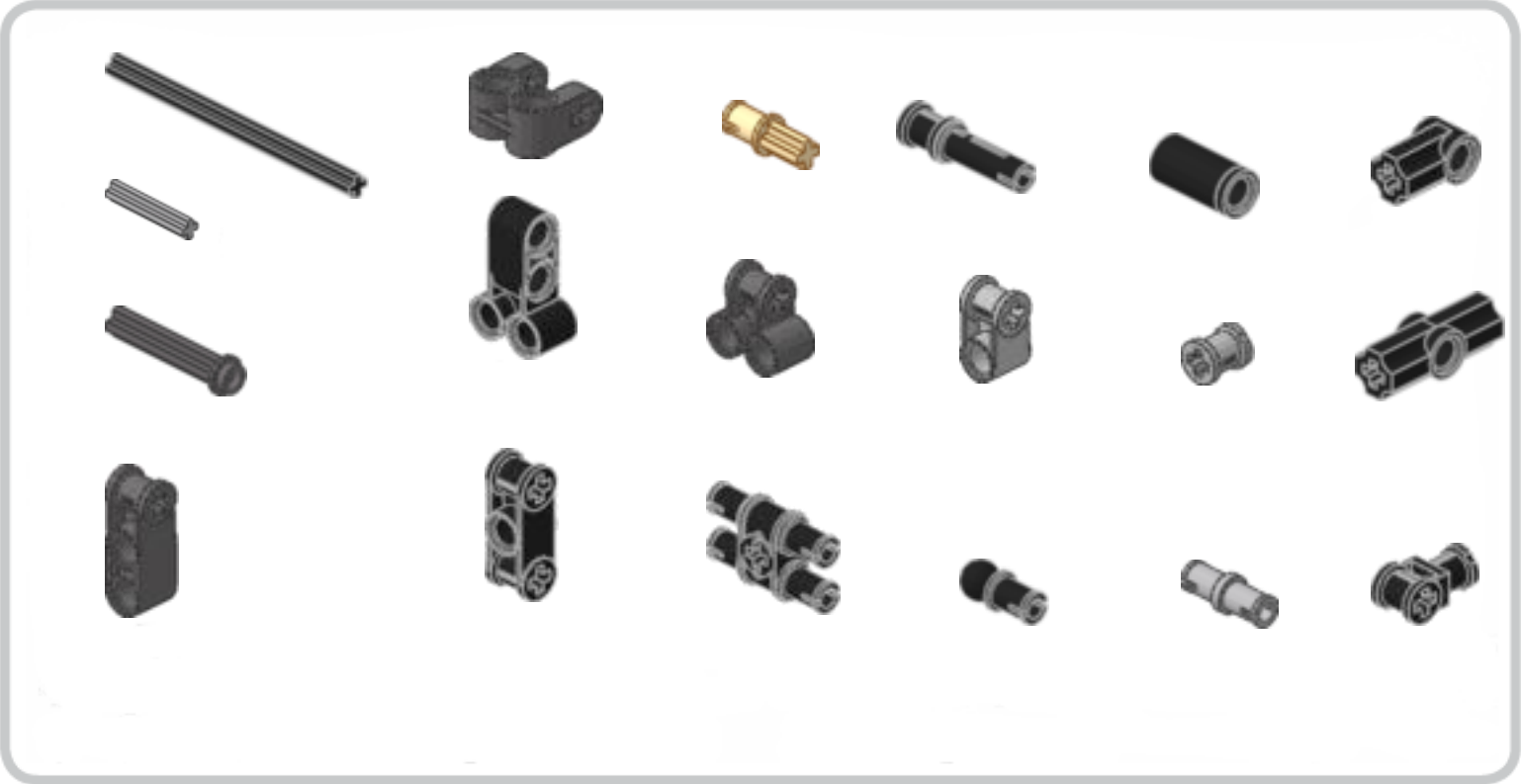

軸

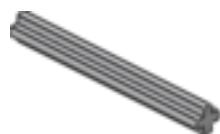
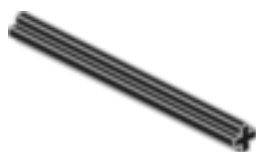

套筒



插銷



軸連接器及插銷連接器



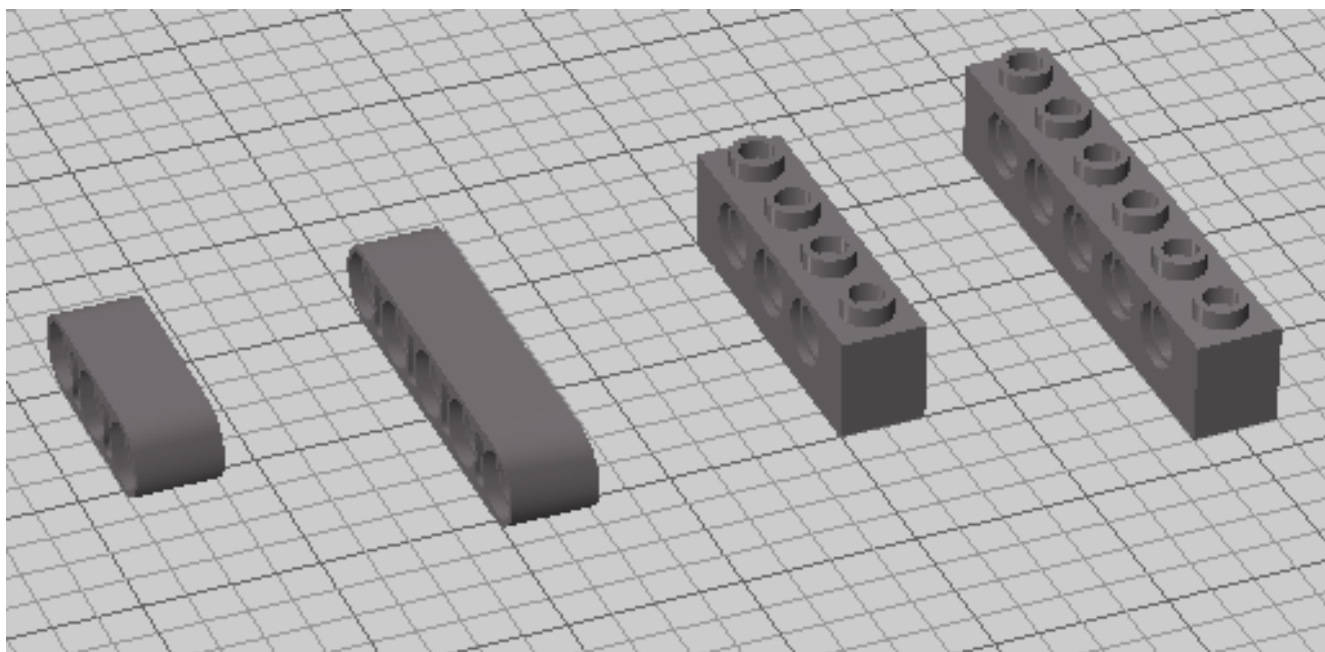

- ▣ 連接器重要性的提昇在於連桿的演變



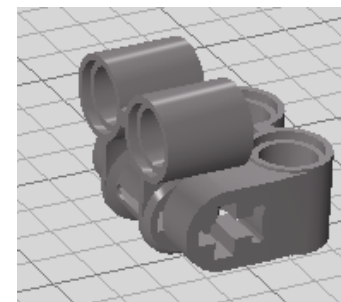
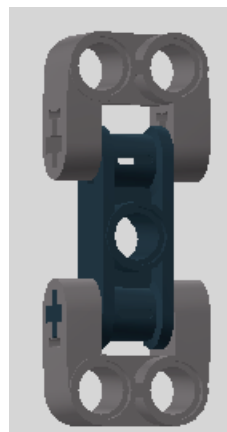
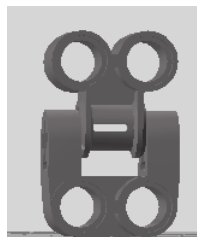
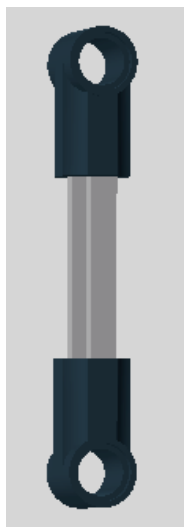

- ▣ 連接器彼此間常用的接合方法



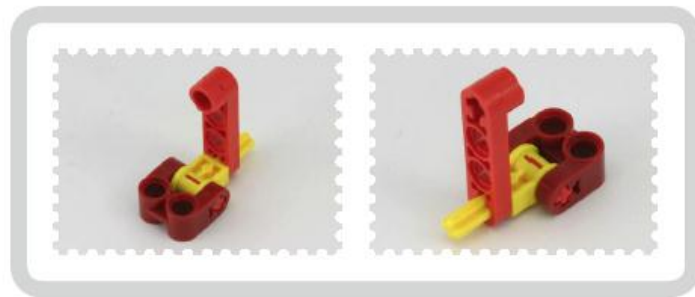
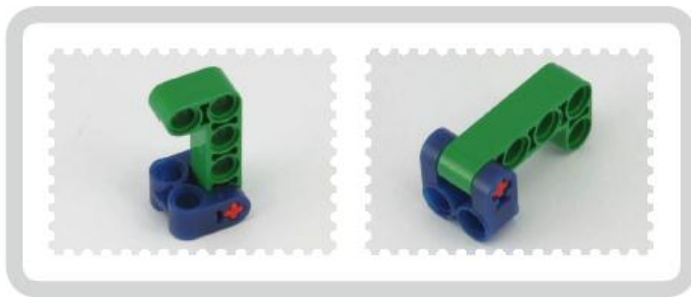
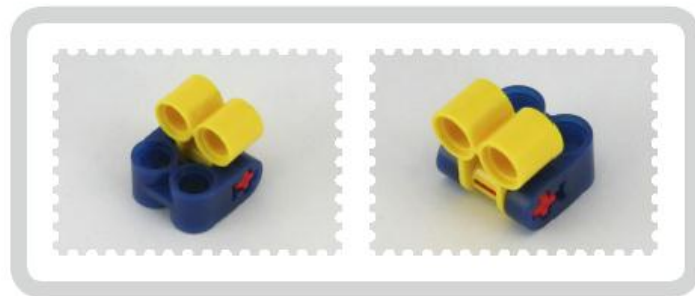
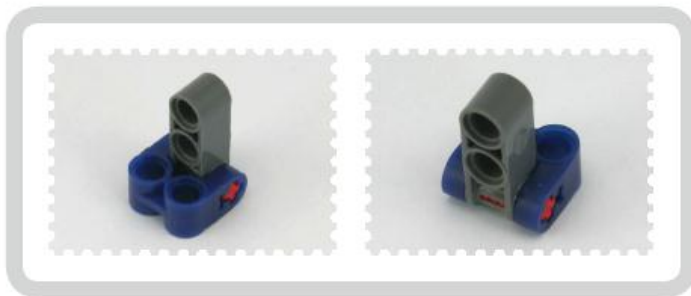
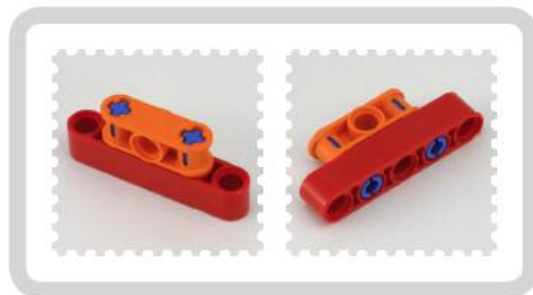

▣ 連接器的功能在於角度的轉換及延長



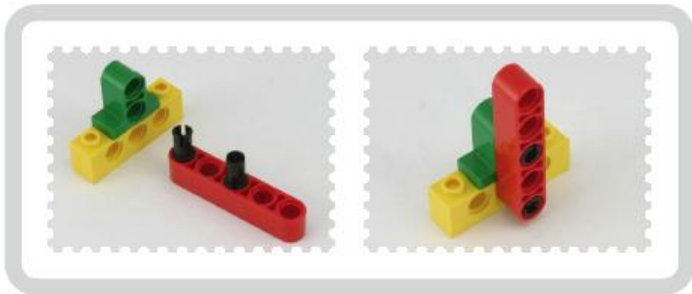
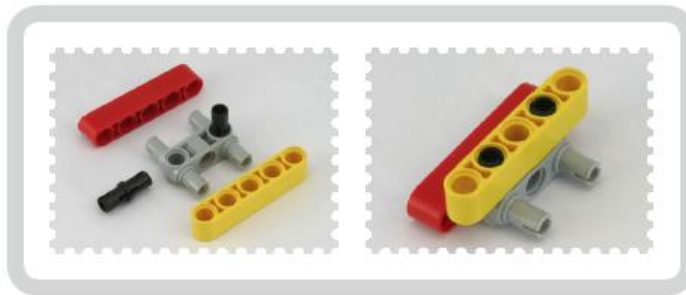
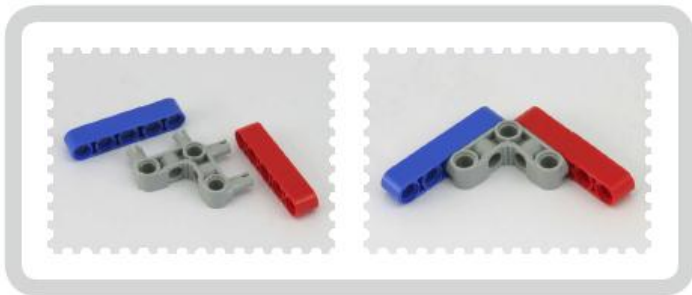
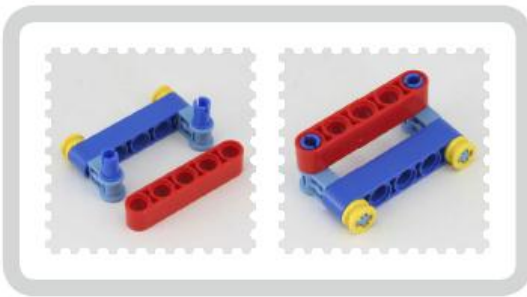

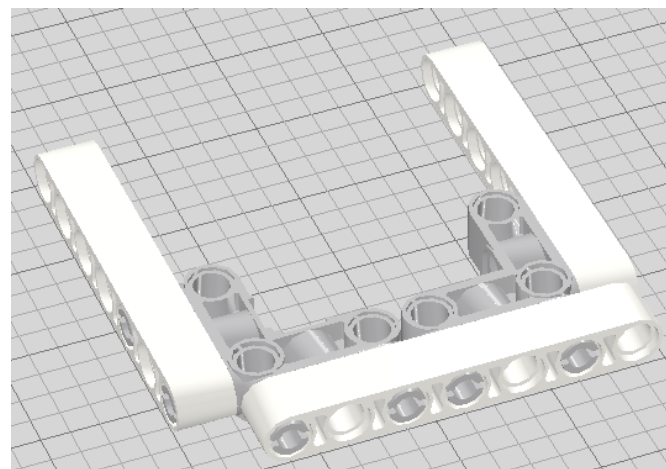
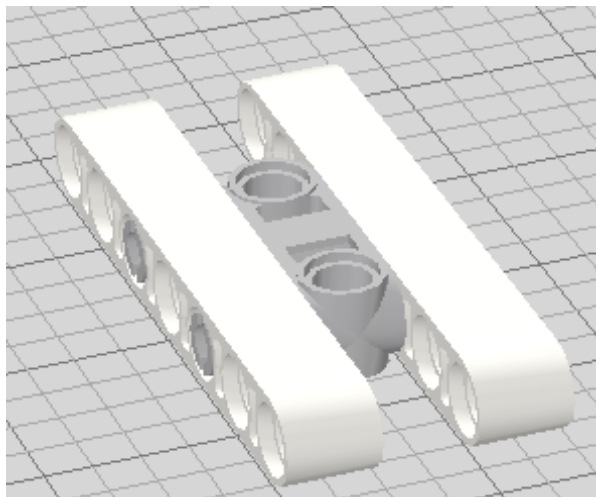

▣ 範例：平行連桿的建構



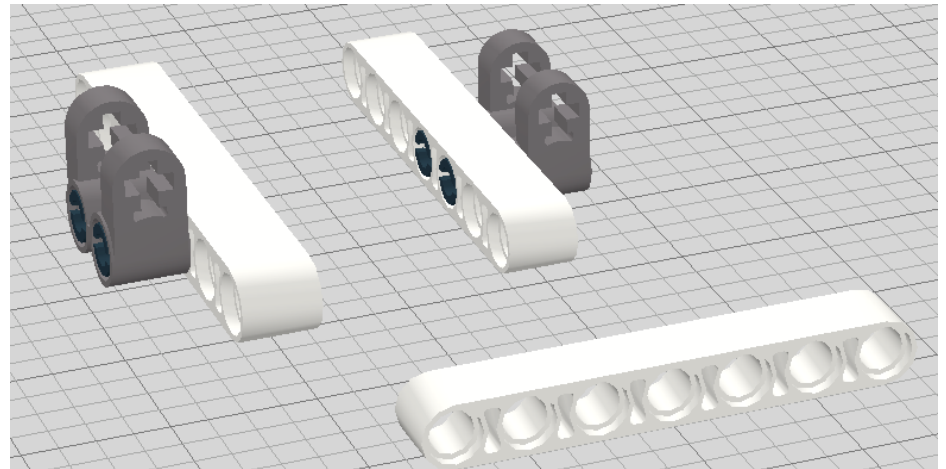
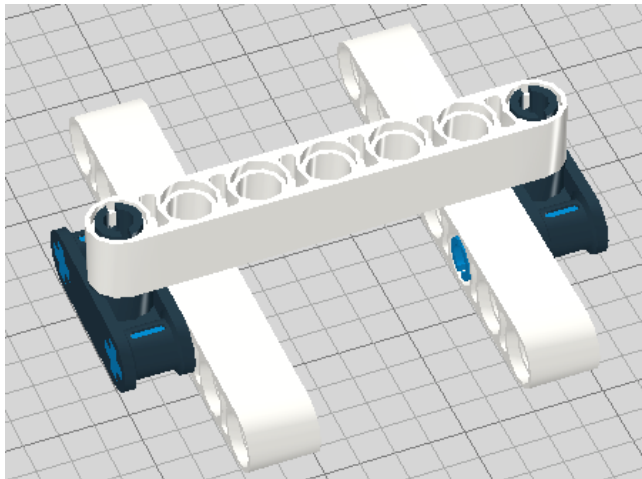

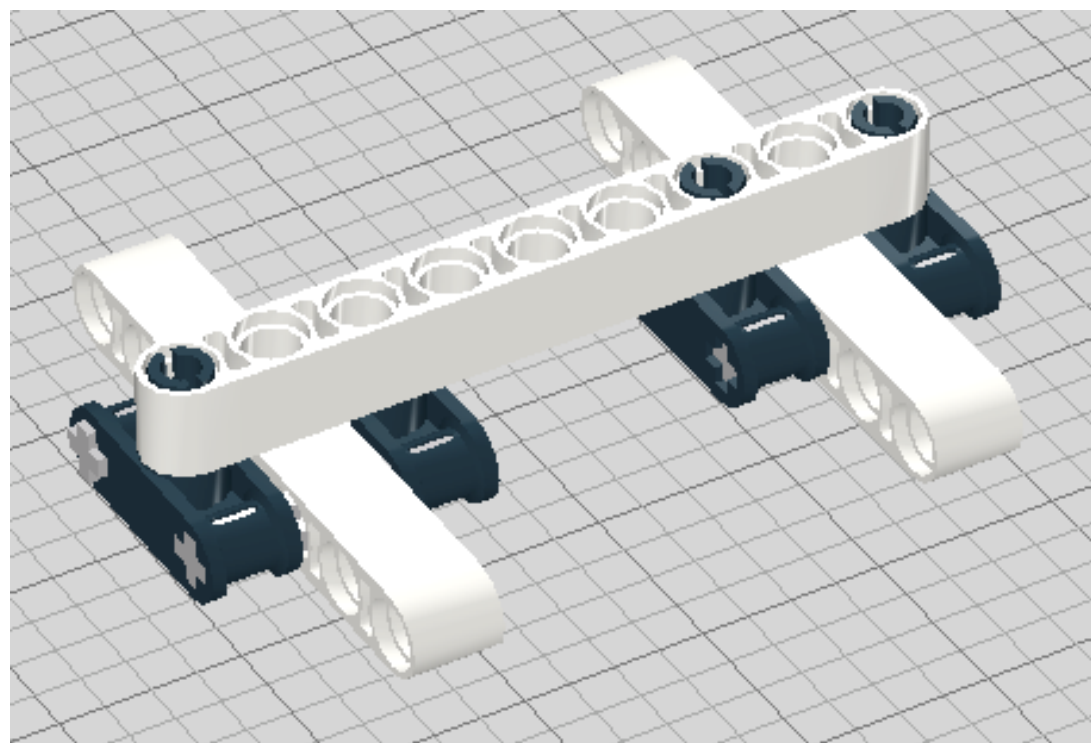

■ 齒輪(Gears)

正齒輪與斜齒輪



其他齒輪

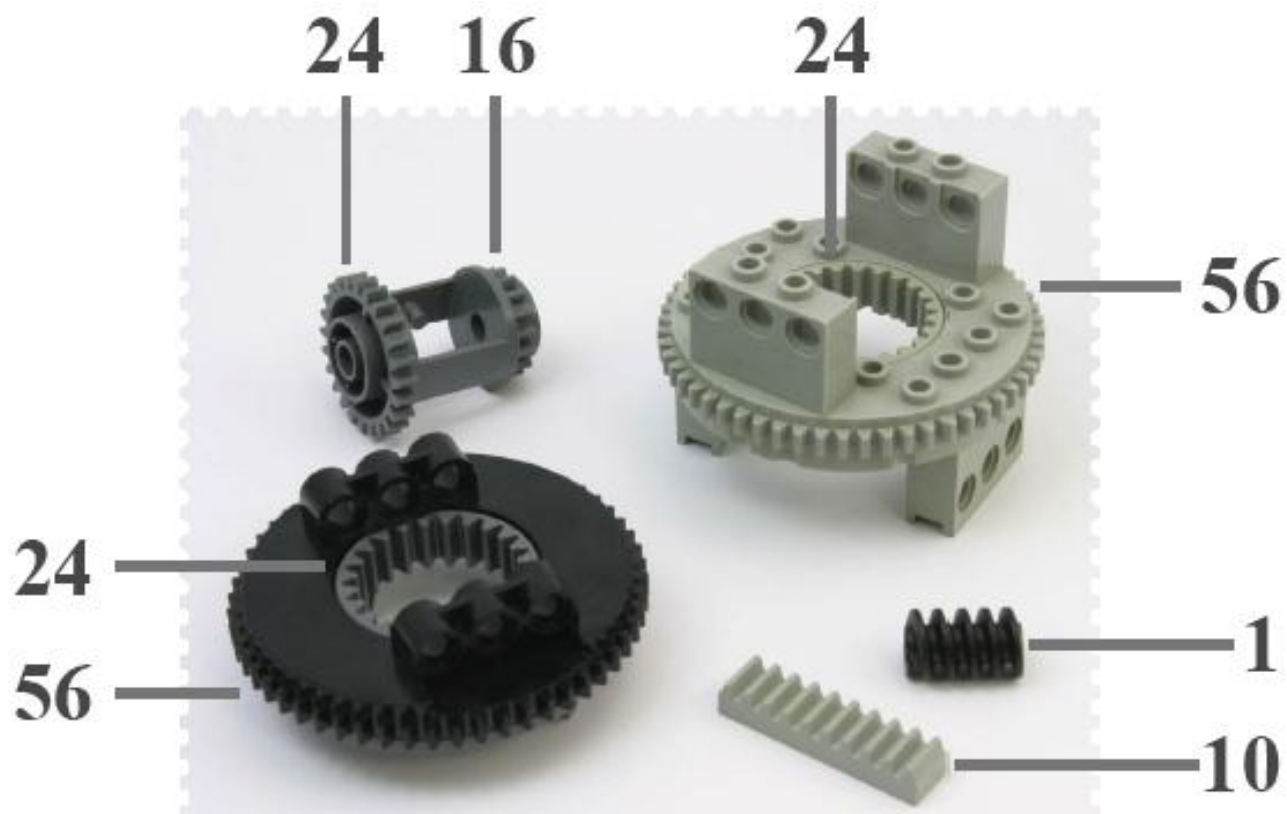

$$n_1\omega_1 = n_2\omega_2$$

$$T_1\omega_1 = T_2\omega_2$$

$$T_1n_2 = T_2n_1$$

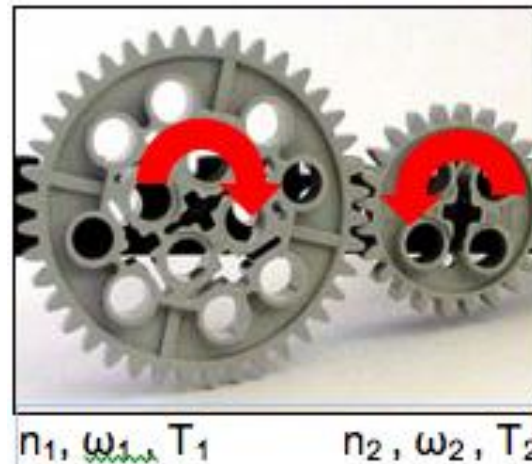

改變扭矩

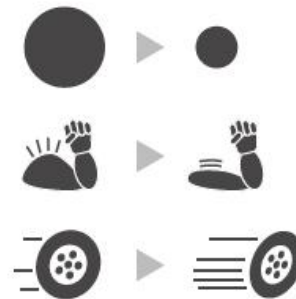
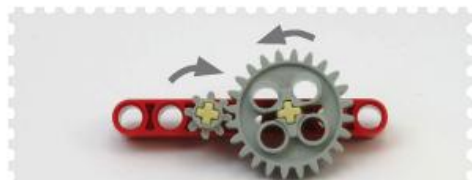

1:1



1:1



惰輪

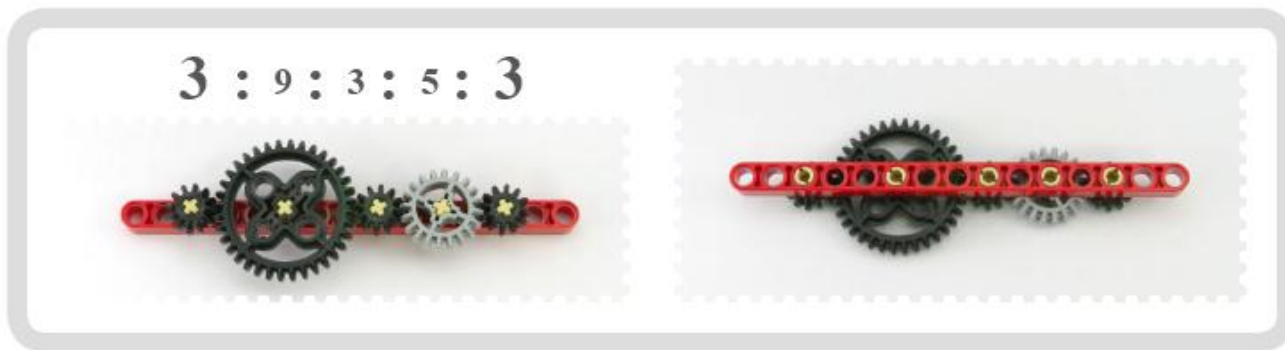

複合齒輪組

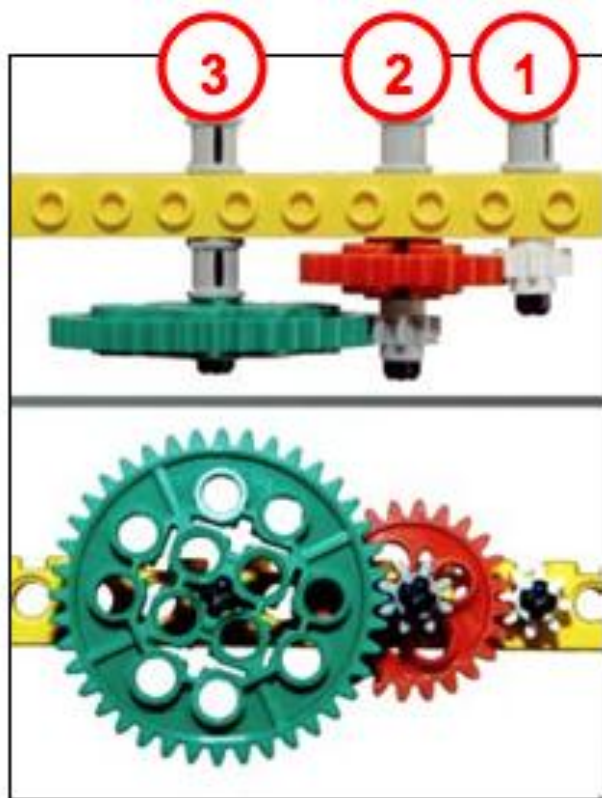

斜齒輪與正齒輪的使用

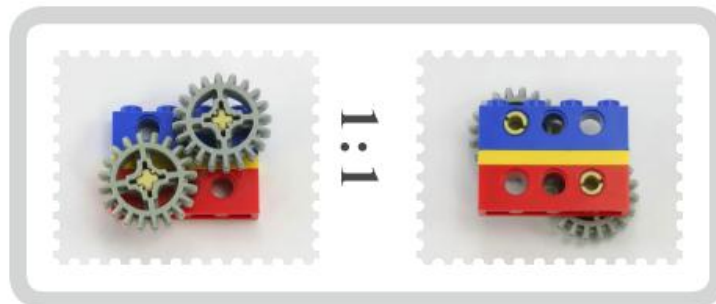
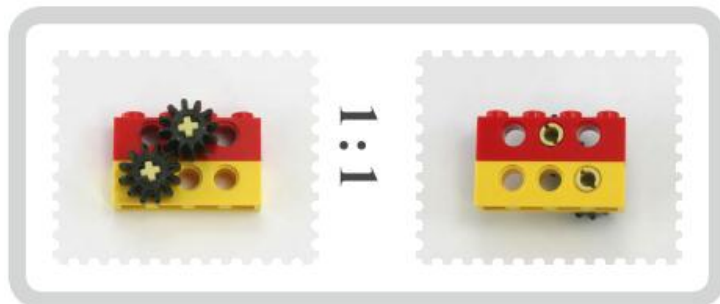
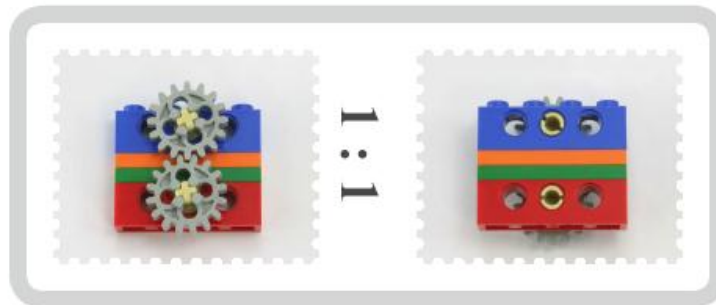
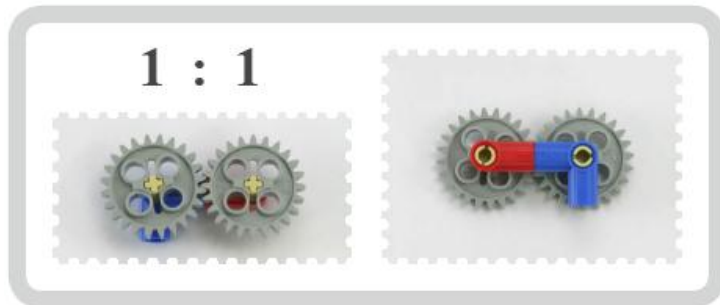

斜齒輪與正齒輪的使用

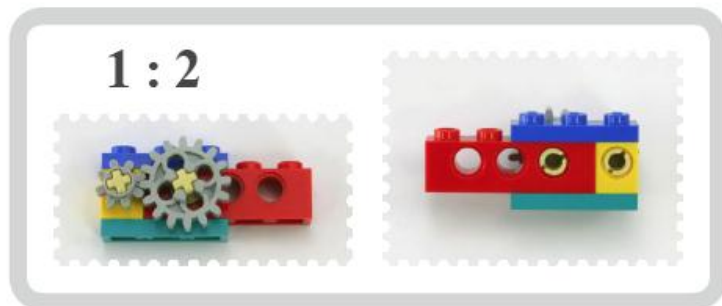
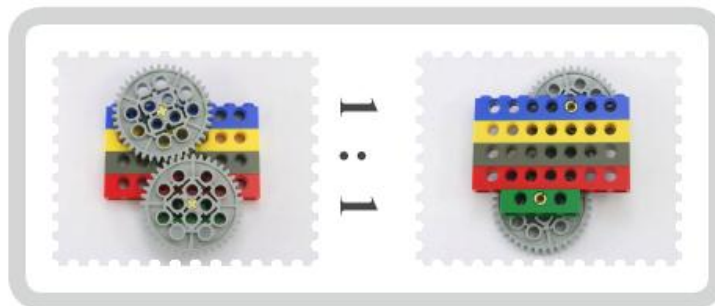
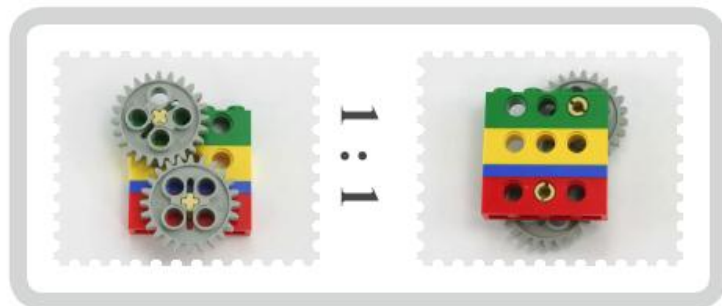

斜齒輪與正齒輪的使用

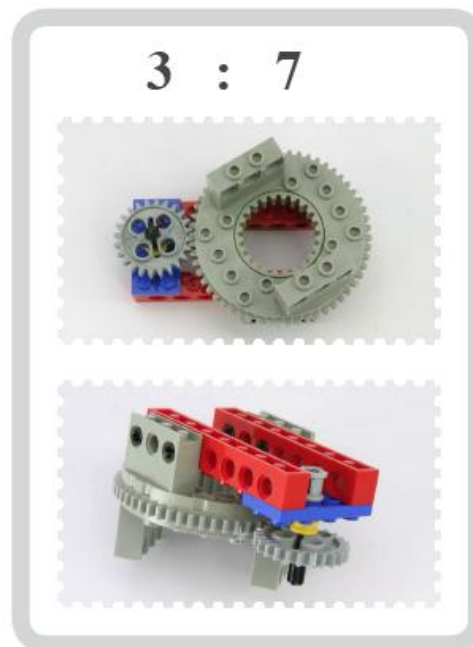

蝸桿的使用



斜齒輪可改變力的方向

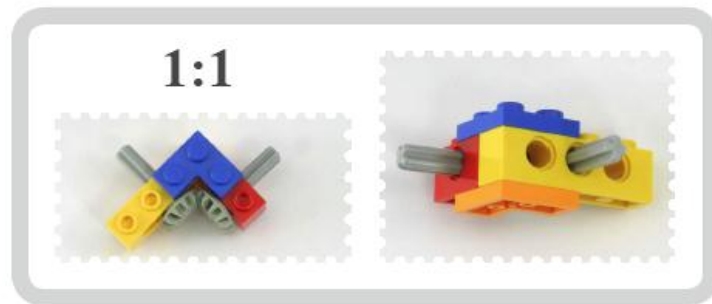

齒條的使用

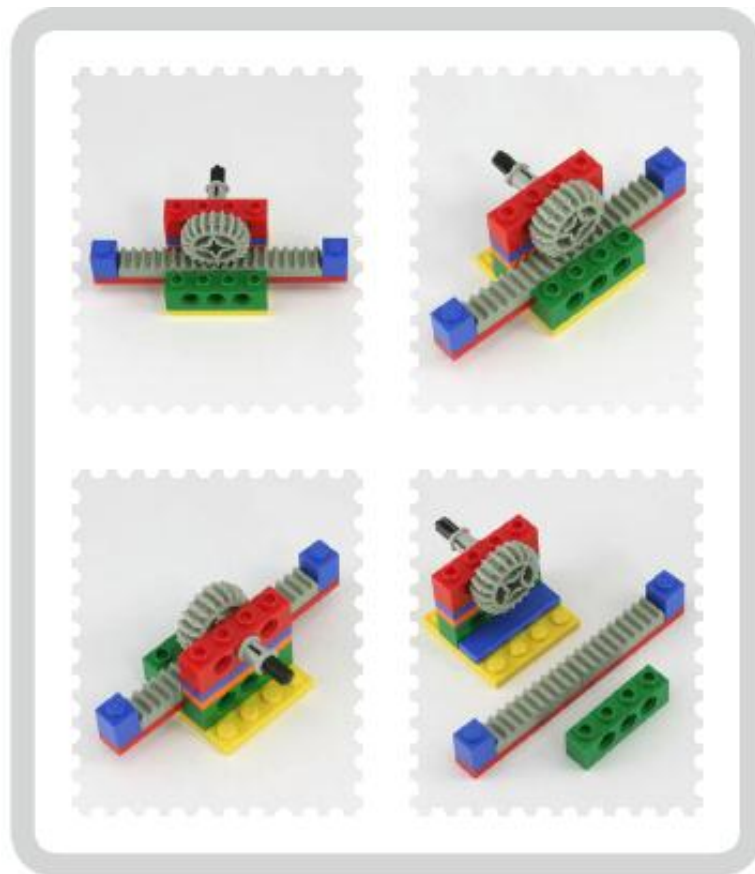

齒條的應用-NXT Climber

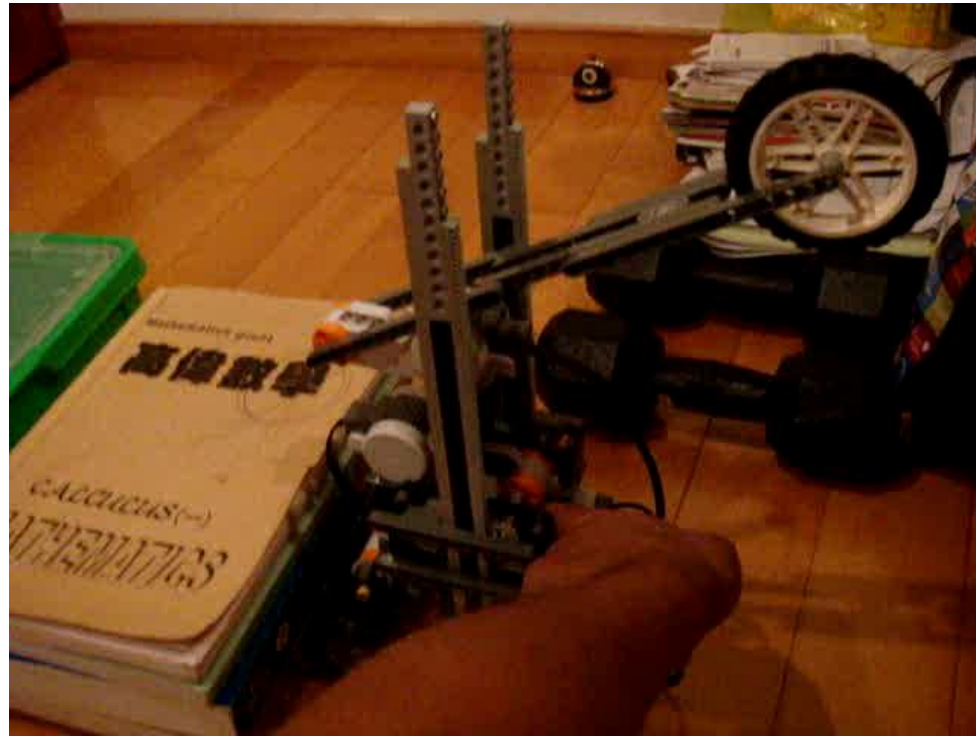
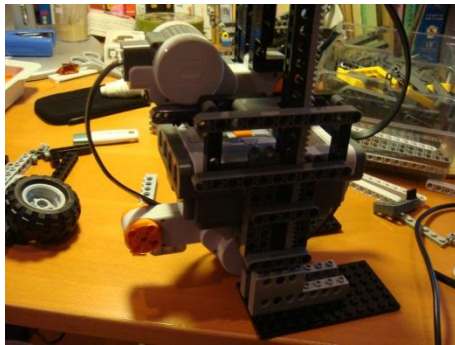
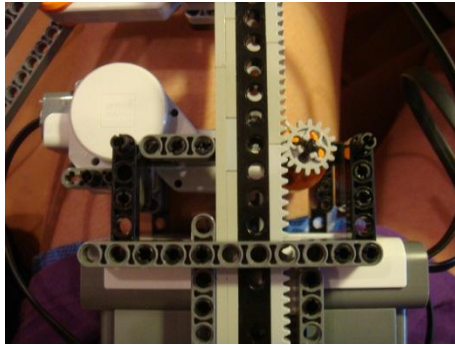

差速器的使用

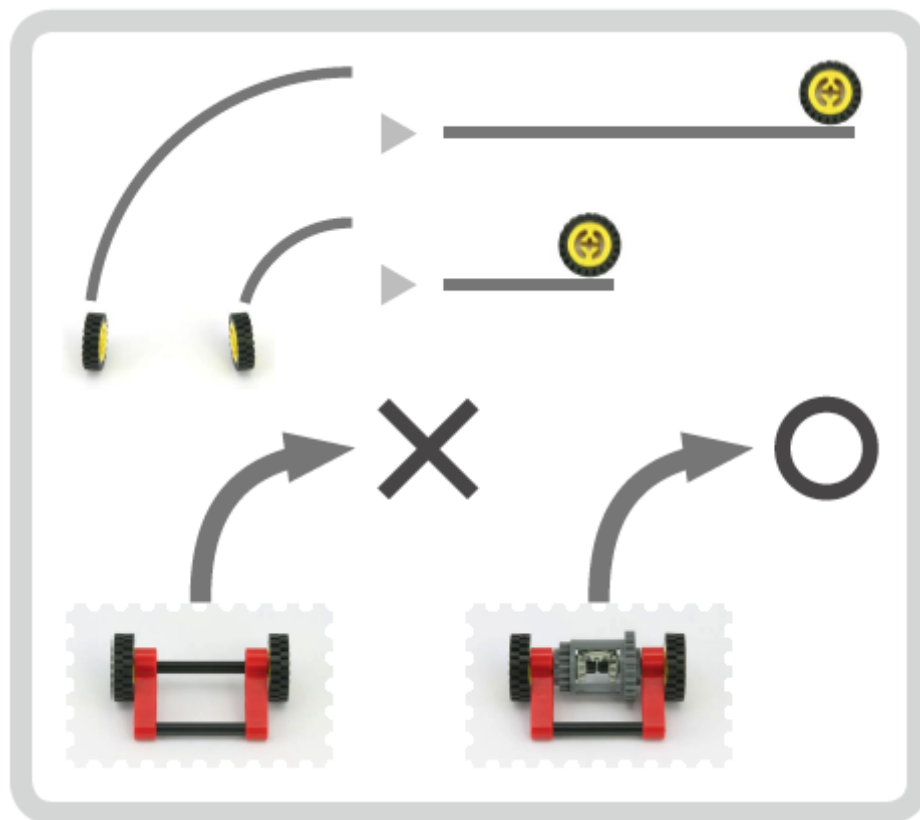
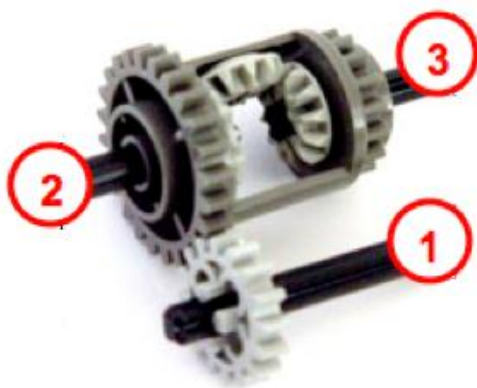

2-SPEED AUTOMATIC GEARBOX by Sarel

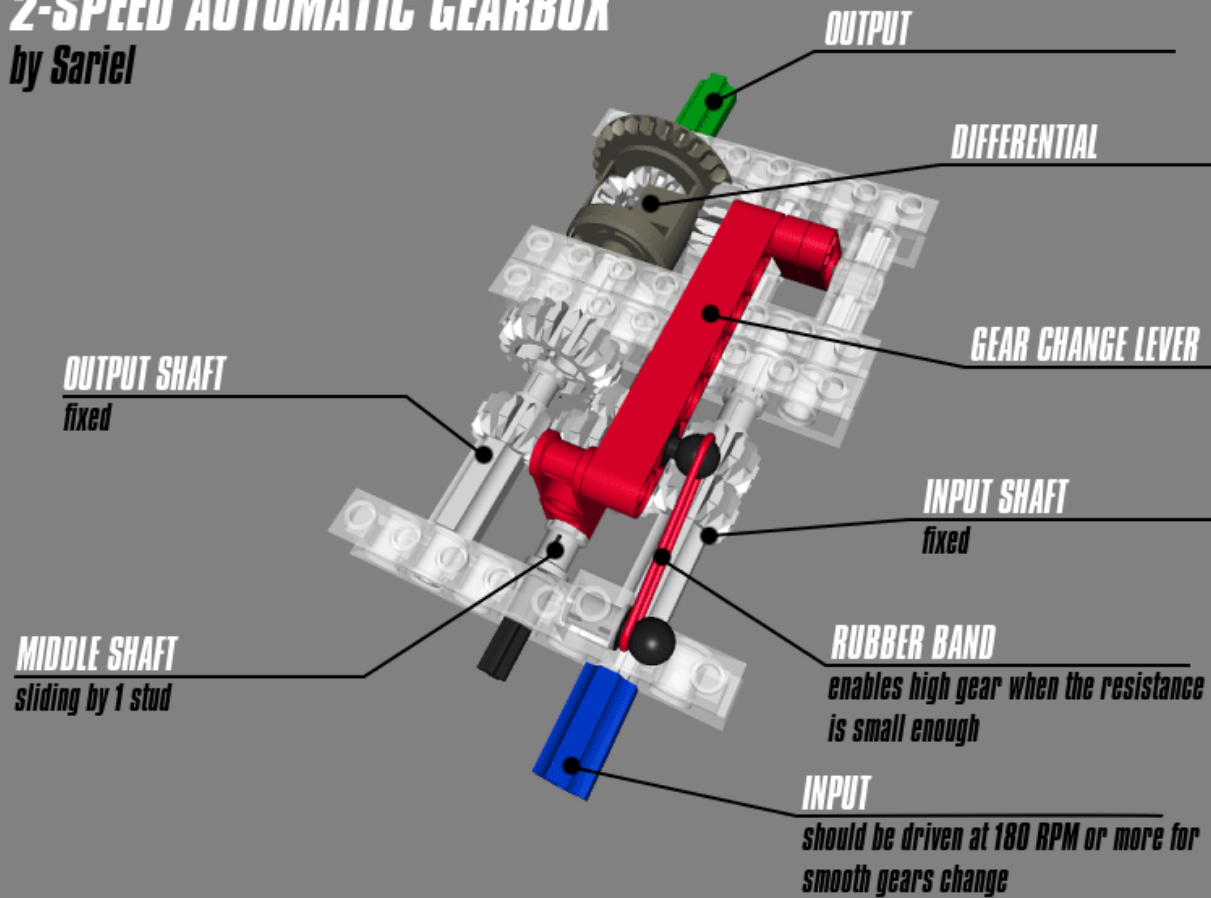

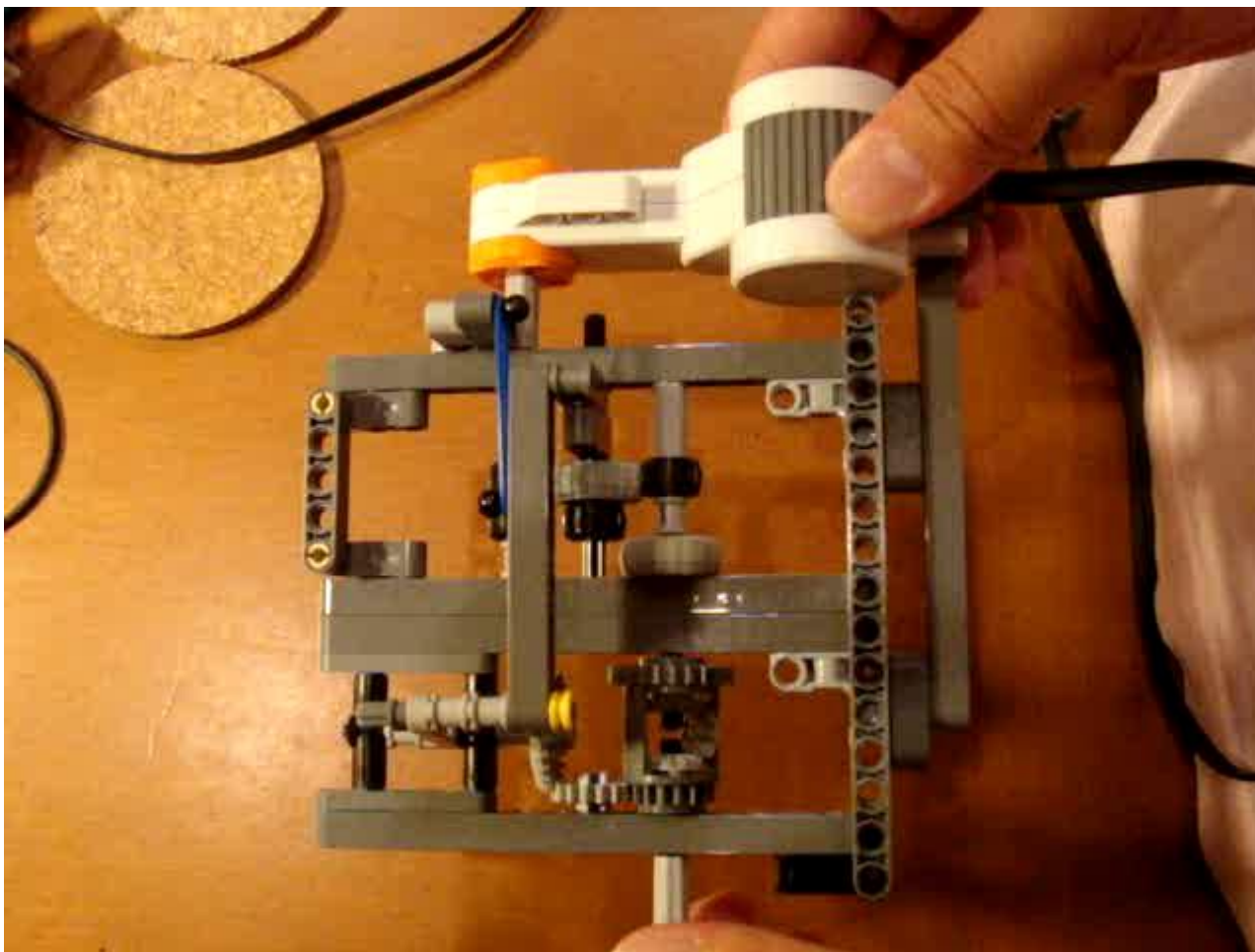

■ 其他 (Miscellaneous elements)



■ 組裝注意事項及範例

更穩固的結構

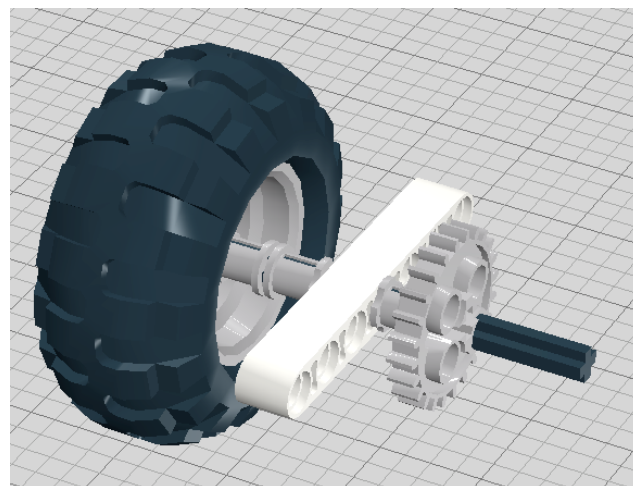
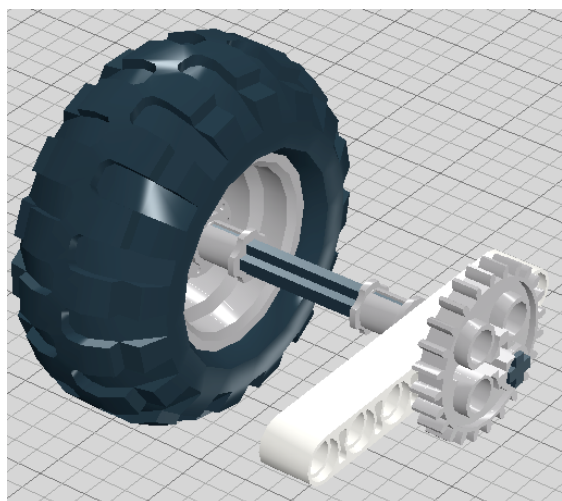

▣ 輪子需盡量靠近連桿



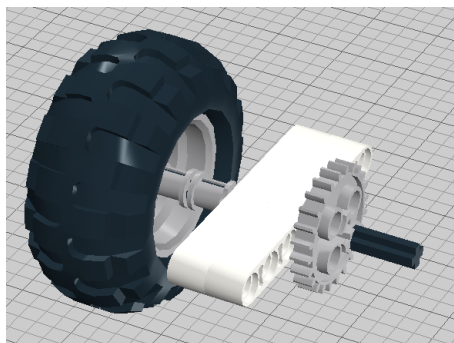

good

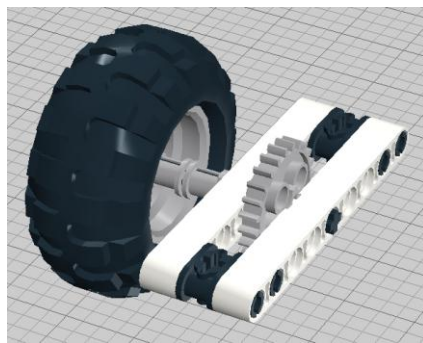
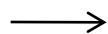

better

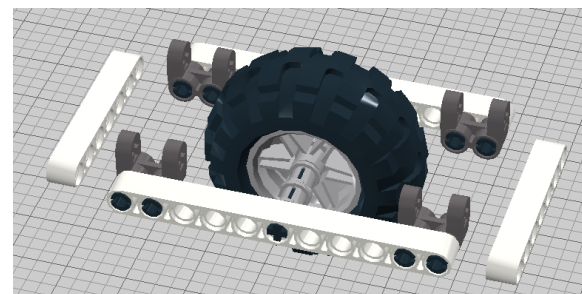
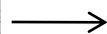

best

■ 兩條連桿支撐勝過一條



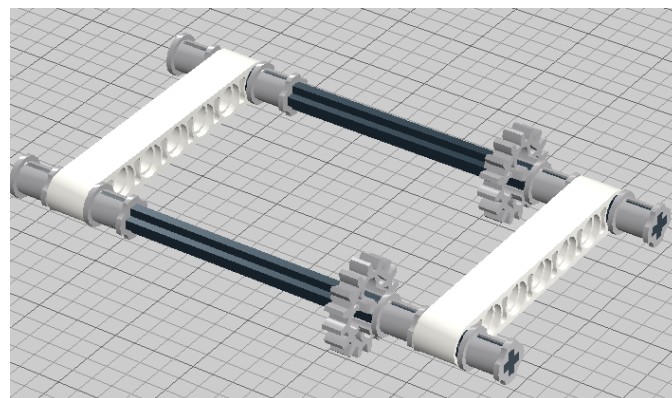
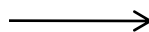
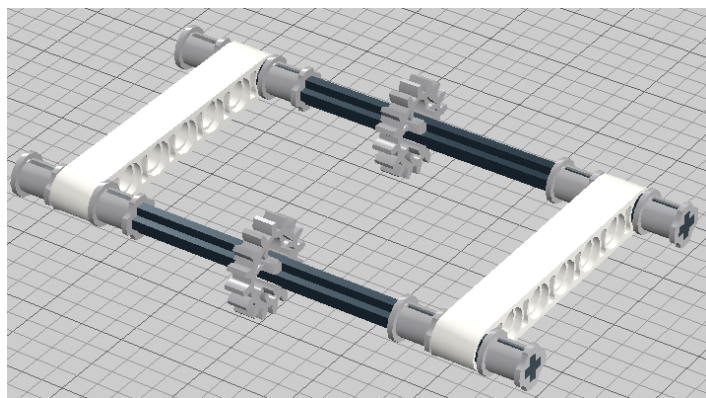

齒輪需靠近支撐的連桿



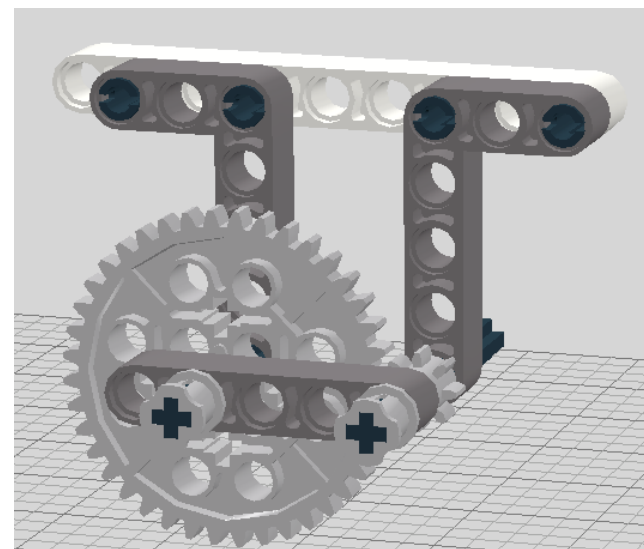
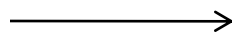
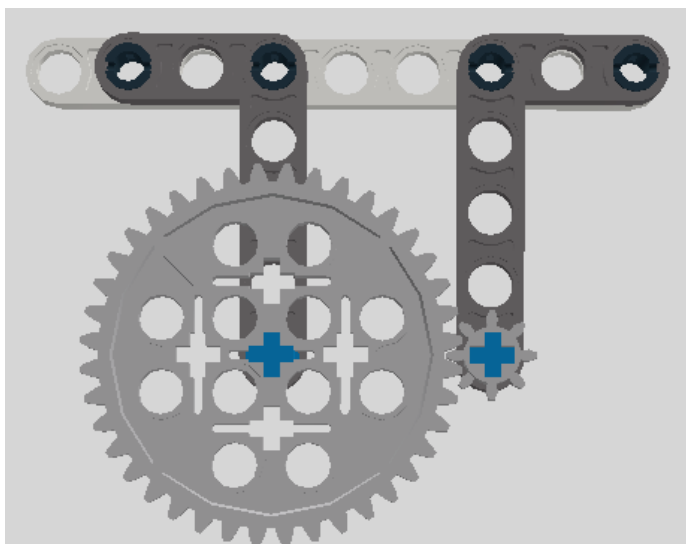

■ 同一列但位處不同連桿的齒輪需外加連桿固定





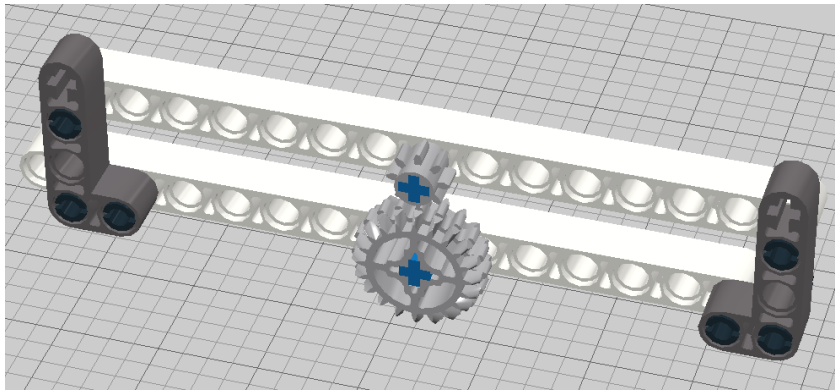

good

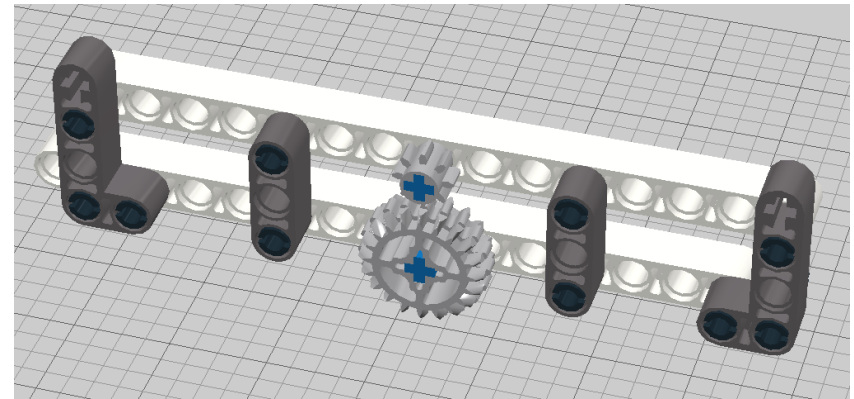

better



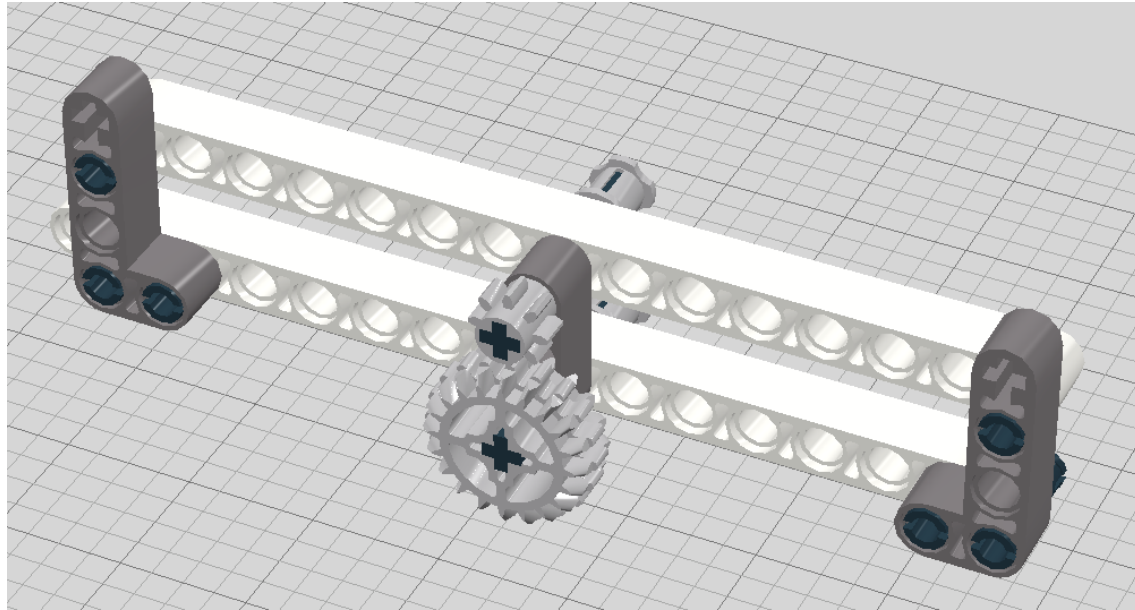

best



- 模組化

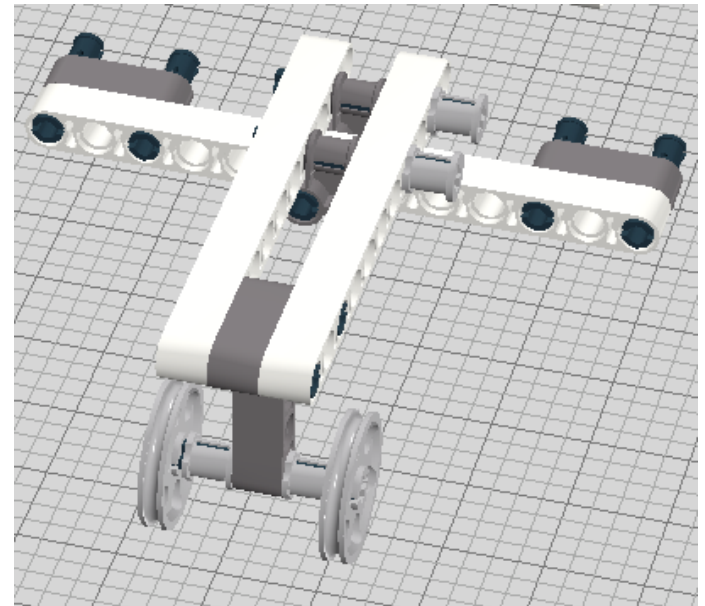
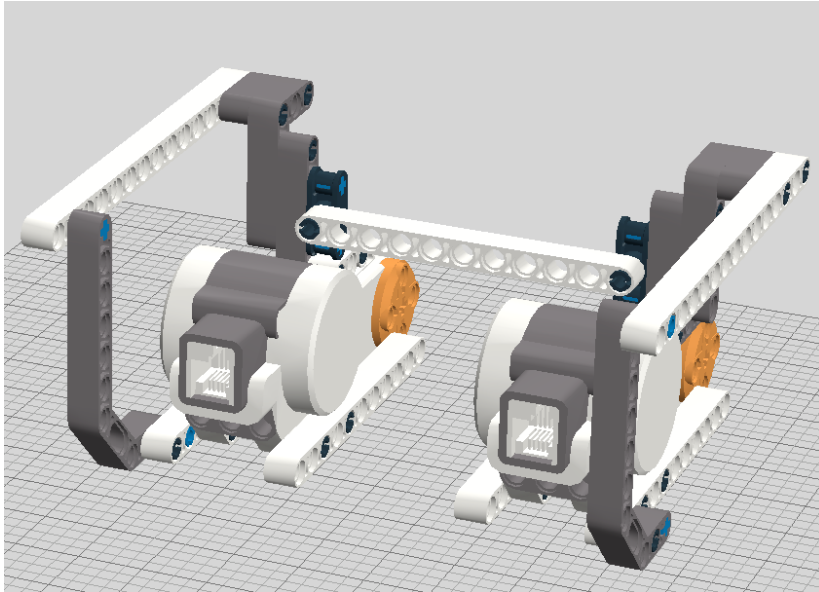

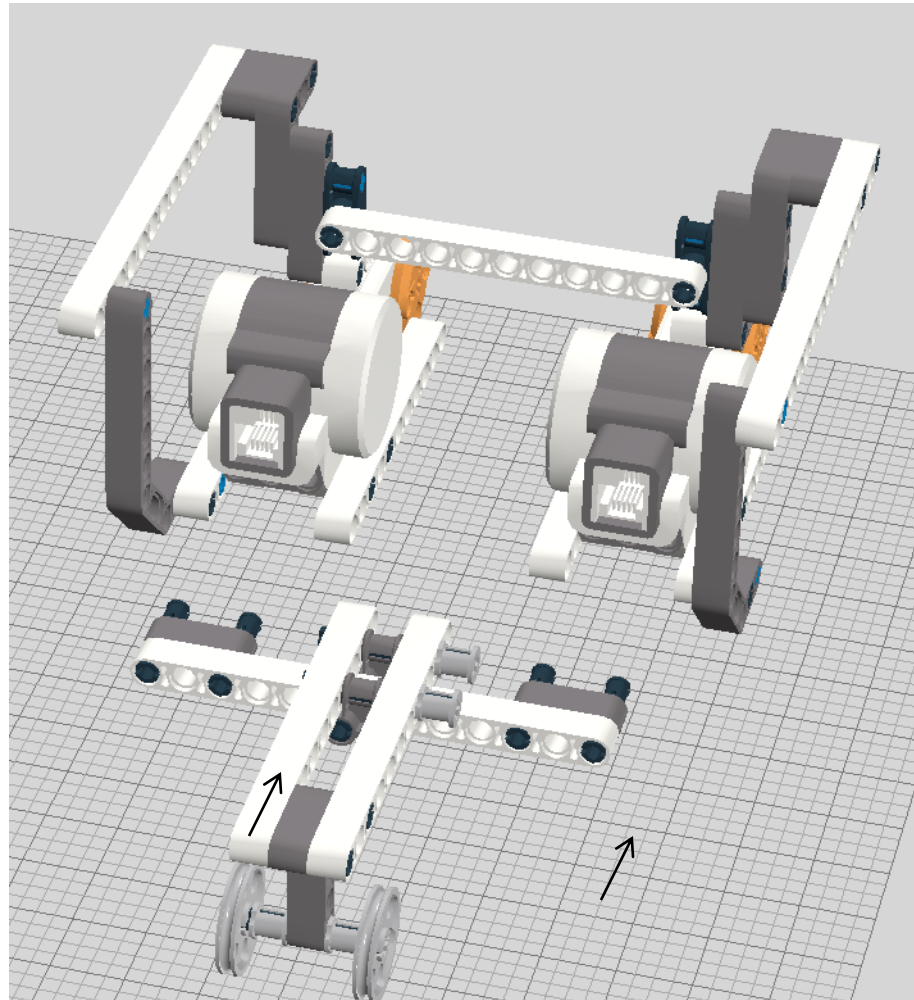

3. 常見車體介紹與實作

- 基本車體
- 連桿式轉向機構
- Synchronized drive
 - Omni drive



■ 基本車體

兩輪驅動 + 萬向輪

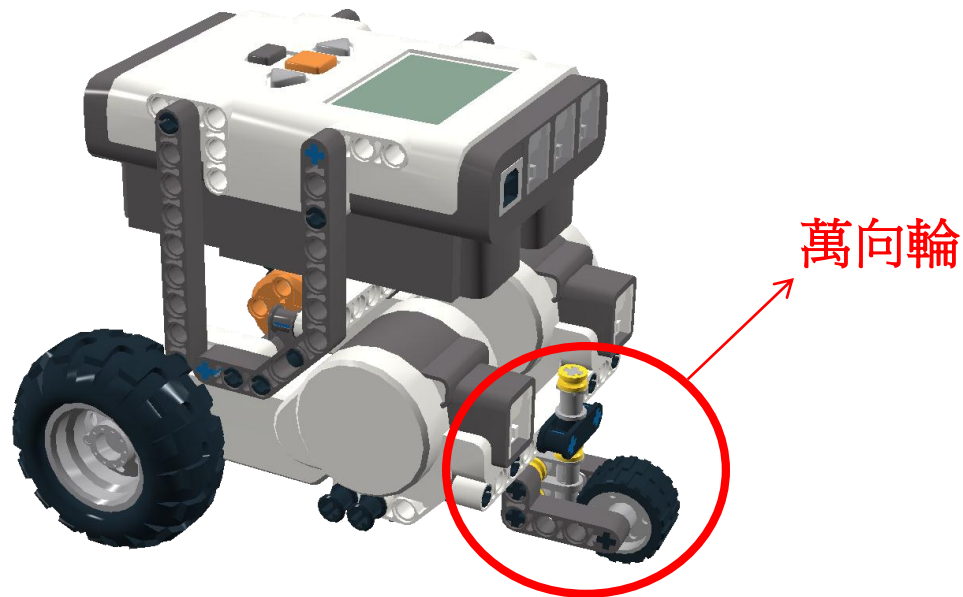

萬向輪的建構

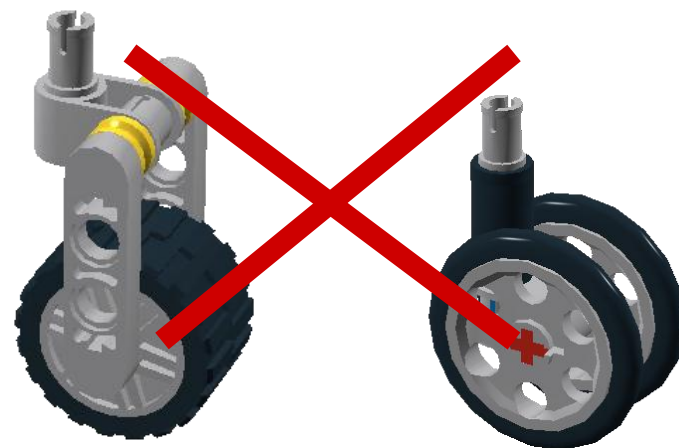
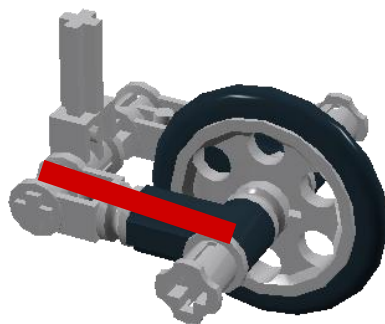
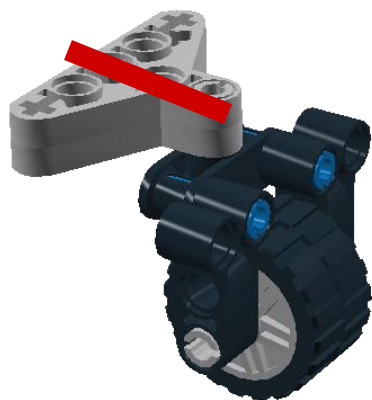

必須有施力臂，才能順暢轉向



■ 連桿式轉向機構

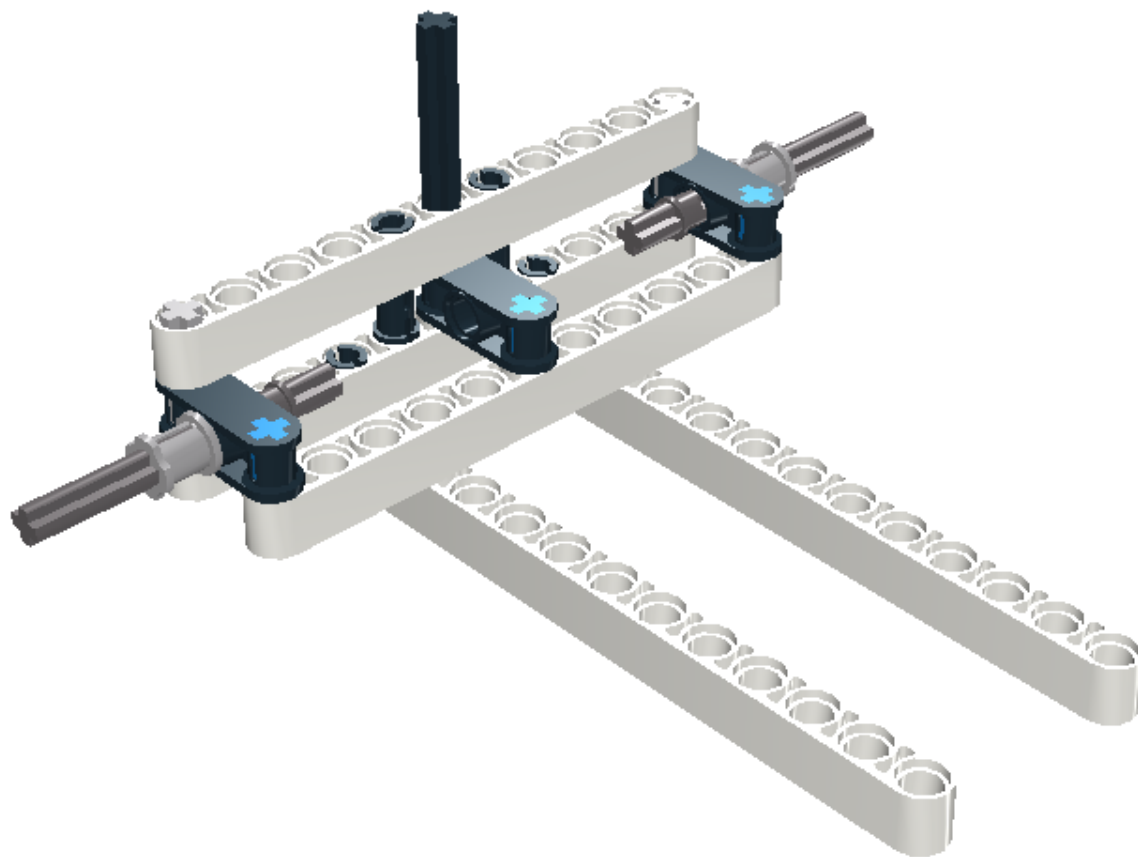

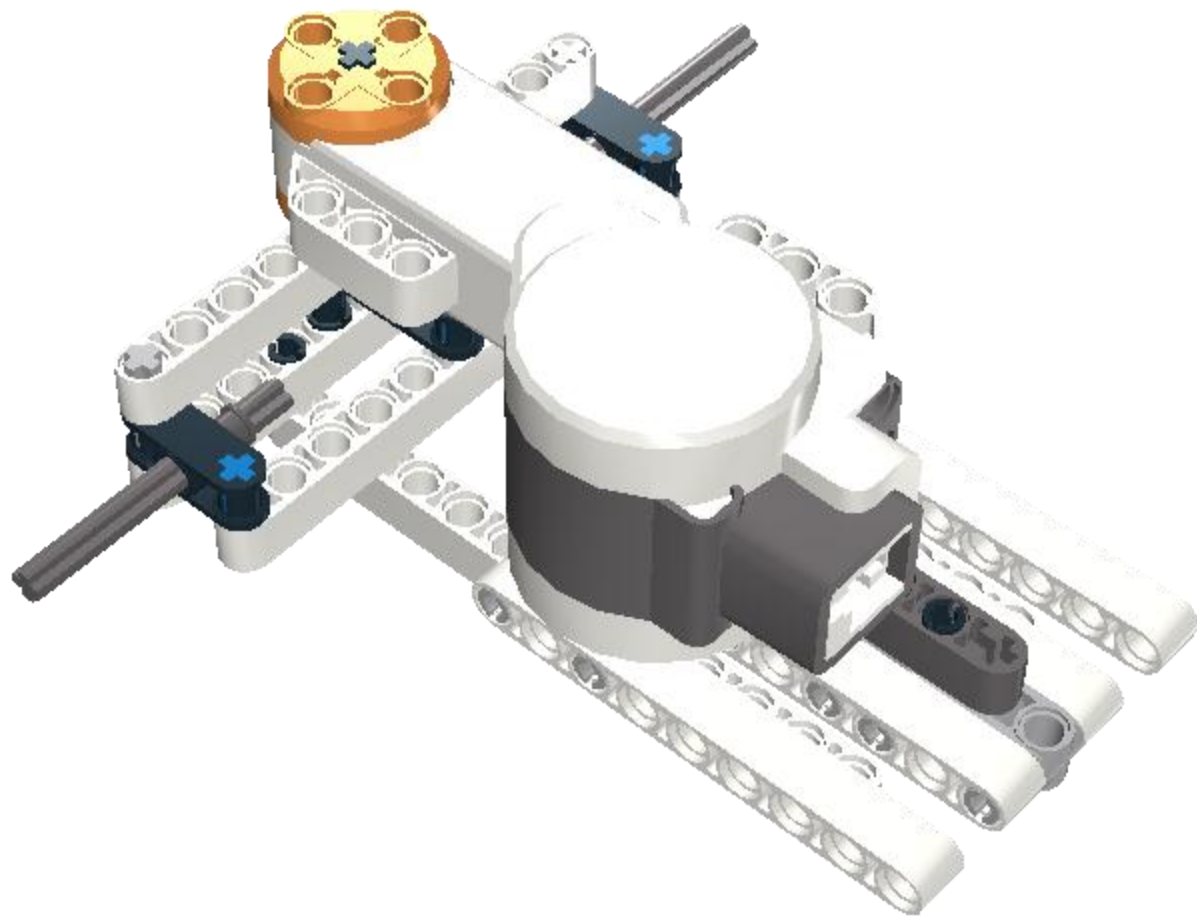

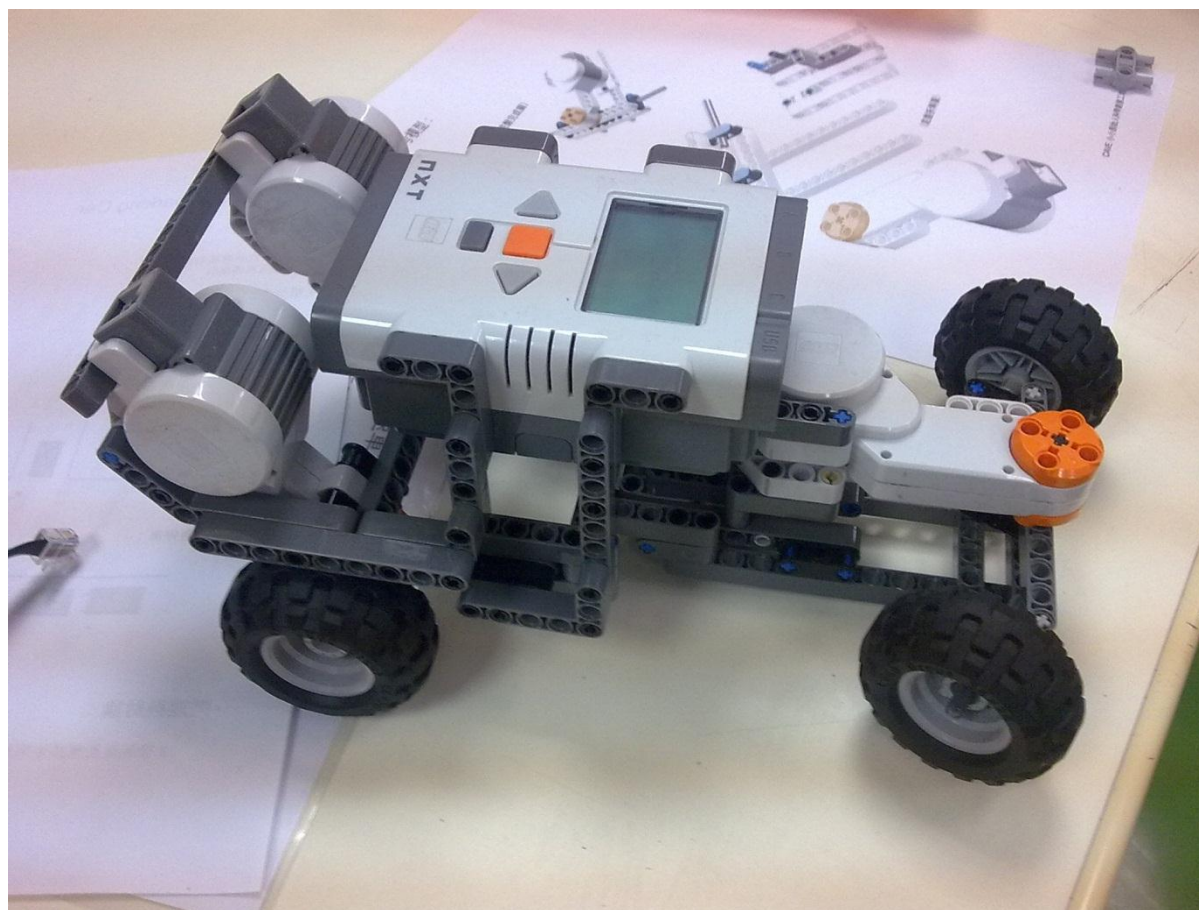



- Synchronized Drive

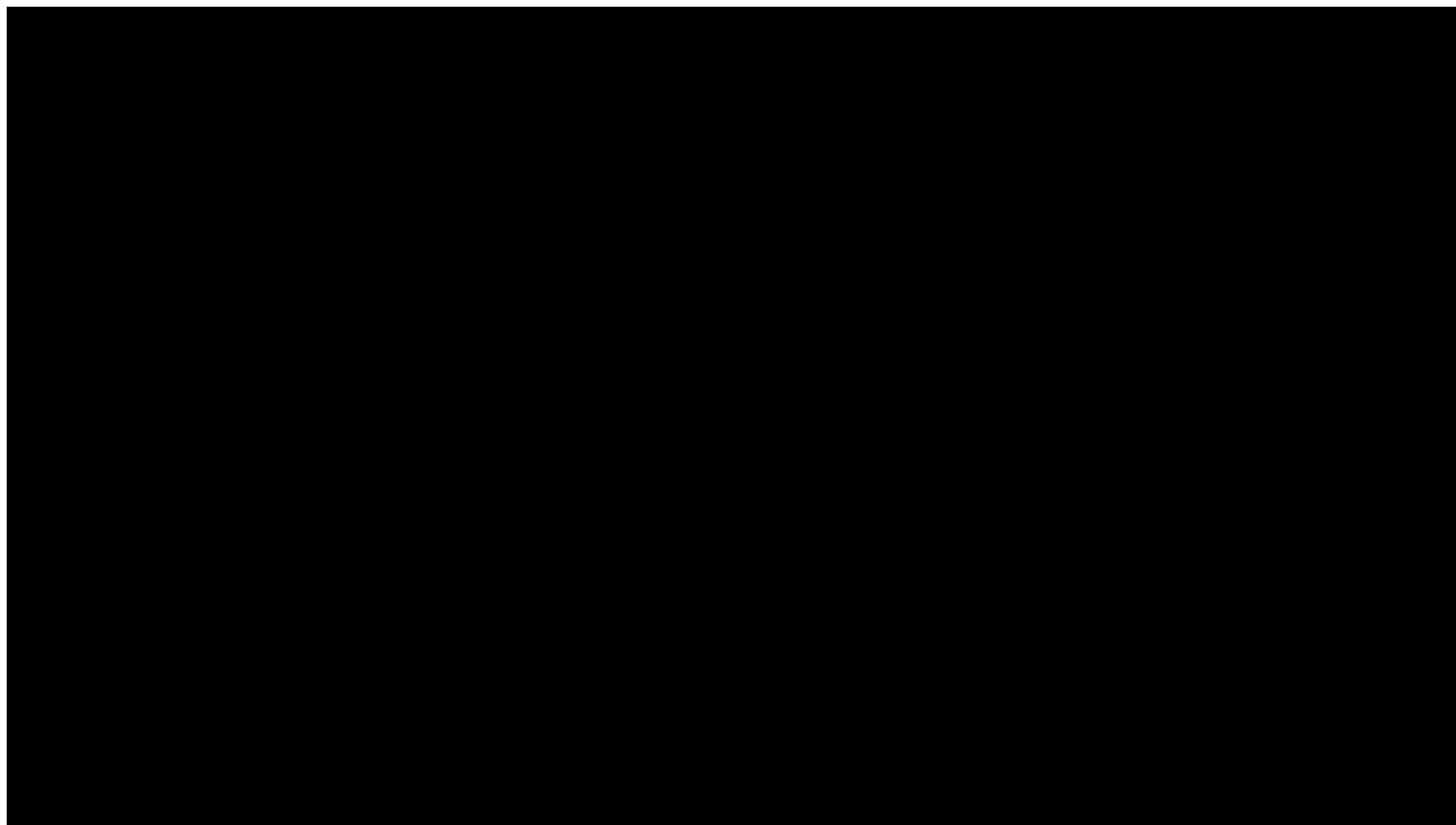

- Omni drive

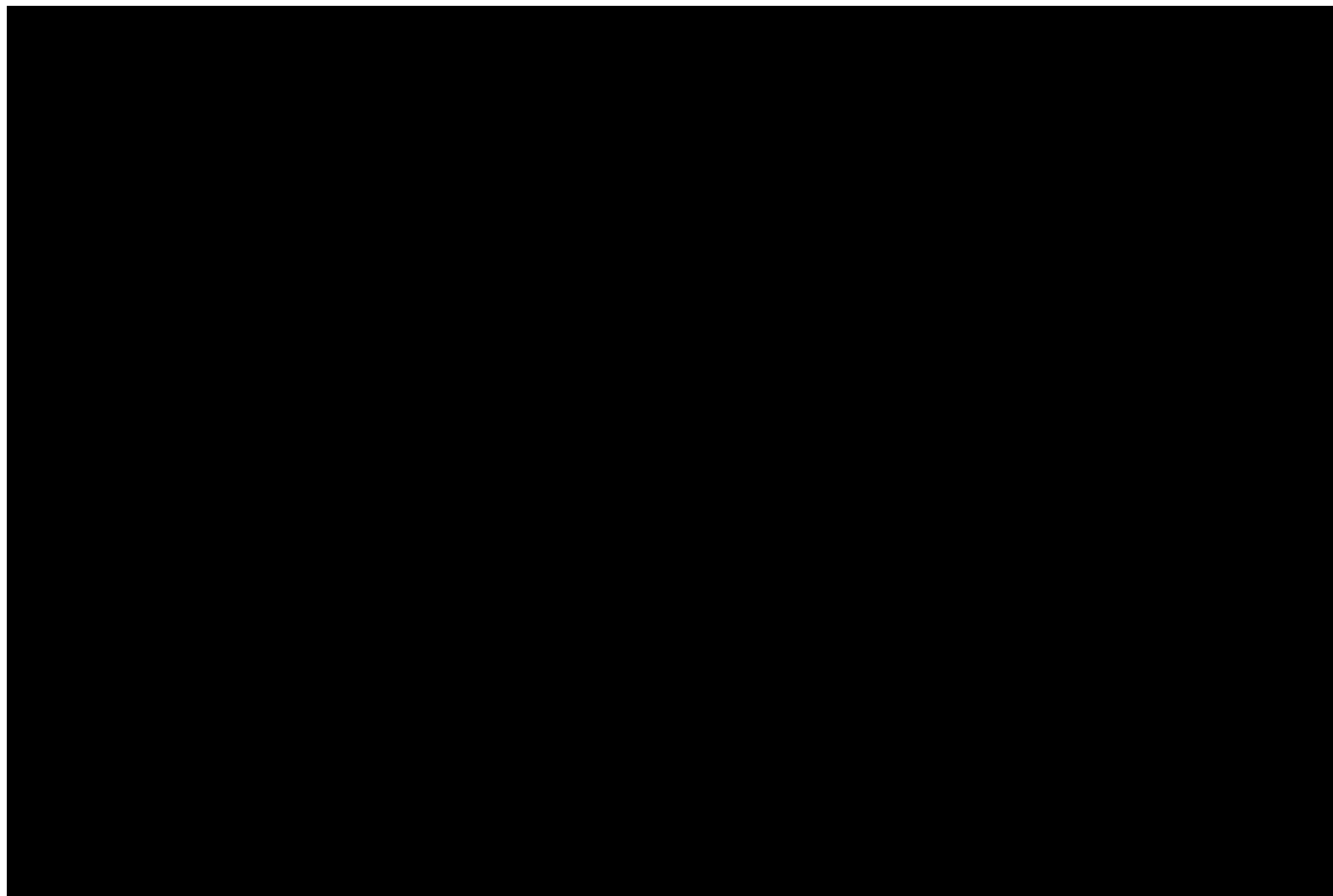

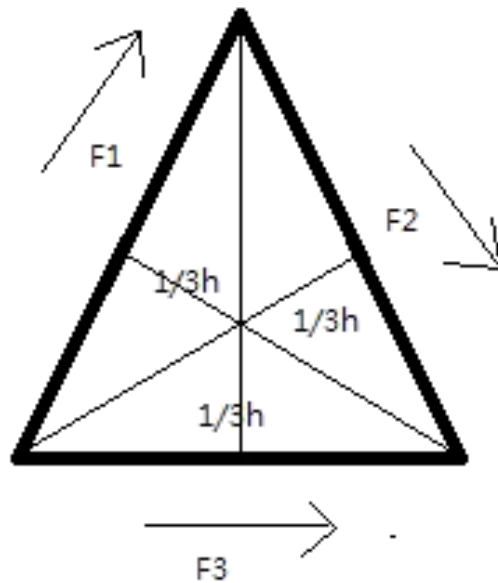

- 分量表示

- $F_{1x} = \cos 60^\circ * F_1$

$$F_{1y} = \sin 60^\circ * F_1$$

- $F_{2x} = \cos 60^\circ * F_2$

$$F_{2y} = \sin 60^\circ * F_2$$

- $F_{3x} = \cos 0^\circ * F_3$

$$F_{3y} = \sin 0^\circ * F_3$$



範例1：機器人資訊

主機名稱

電量

韌體版本

當前正在運行的程式

藍牙實體名稱



執行過程

1. 將手機與NXT進行藍牙配對
2. 由手機發起連線
3. 擷取NXT資訊
4. 顯示在手機畫面上



如果用Java來寫的話，很複雜

```
using System;
using System.Collections.Generic;
using System.ComponentModel;
using System.Data;
using System.Drawing;
using System.Text;
using System.Windows.Forms;
using NxtMindSpalls;

namespace NetRemotel
{
    public partial class Form1 : Form
    {
        private NxtBrick brick;
        private NxtMotorSync motorPair;

        public Form1()
        {
            InitializeComponent();
            this.Text = "Disconnected";
        }

        private void btnConnect_Click(object sender, EventArgs e)
        {
            try
            {
                byte comPort = byte.Parse(this.txtComPort.Text);
                brick = new NxtBrick(comPort);
                brick.MotorB = new NxtMotor();
                brick.MotorC = new NxtMotor();
                motorPair = new NxtMotorSync(brick.MotorB, brick.MotorC);
                brick.Connect();
                this.Text = "Connected: " + brick.Message;
            }
            catch { }
        }
    }
}

private void btnConnect_Click(object sender, EventArgs e)
{
    try
    {
        SerialPort
        PortName = "COM10" //<<<< Change this number for your computer
        BaudRate = 9600
        Parity = 10.Parity.None
        DataBits = 8
        StopBits = 10.Ports.StopBits.One
        ReadTimeout = 300 //30ms
        WriteTimeout = 300 //30ms
        With
        ...ll.Text = "Connected"
        Catch ex As Exception
        MsgBox(ex.ToString)
        End Try
    End Sub

    Private Sub Button2_Click(ByVal sender As System.Object, ByVal e As System.EventArgs) Handles Button2.Click
        Dim byteIn(5) As Byte
        Dim byteIn(6) As Byte
        Dim Voltage, i As Integer
        Try
            byteOut(0) = &H "02" bytes in output message
            byteOut(1) = &H "00" should be 0 for NCT
            byteOut(2) = &H "00" = reply expected &H00 = no reply expected
            byteOut(3) = &H "00" = read battery command
            SerialPort.WriteLine(byteOut, 0, 4) '0 = offset into byteOut and 4 = number of bytes
            'now read the reply
            byteIn(0) = SerialPort.ReadByte ' number of bytes in message
            byteIn(1) = SerialPort.ReadByte ' should be 0 for NCT
            For i = 2 To 1 + byteIn(0) ' and rest of message
                byteIn(i) = SerialPort.ReadByte()
            Next
            Voltage = byteIn(5) + byteIn(6) * 256 ' the voltage has low byte in 5 and high in 6
        Catch ex As Exception
            MsgBox(ex.ToString)
        End Try
    End Sub
}
```



新增元件

The screenshot displays the LEGO Mindstorms NXT software interface. At the top, there are menu options: "NXT_Information", "Save", "Save As", "Checkpoint", "Open the Blocks Editor", and "Package for Phone".

The interface is divided into several panels:

- Palette:** A list of components categorized into "Basic" (Button, Canvas, CheckBox, Clock, Image, Label, ListPicker, PasswordTextBox, TextBox, TinyDB), "Media", "Animation", "Social", "Sensors", "Screen Arrangement", "LEGO® MINDSTORMS®", "Other stuff", "Not ready for prime time", and "Old stuff".
- Viewer:** A central workspace showing a screen titled "Screen1" with a status bar at the top displaying "5:09 PM". The screen content includes:
 - A checkbox labeled "Display Invisible Components in Viewer".
 - Two buttons: "藍芽裝置連線" (Bluetooth Device Connection) and "中斷藍芽連線" (Disconnect Bluetooth Connection).
 - Five text labels: "Text for Label1", "Text for Label2", "Text for Label3", "Text for Label4", and "Text for Label5".
- Components:** A list of components currently on the screen:
 - Screen1 (expanded)
 - ListPickerConnect
 - Label1, Label2, Label3, Label4, Label5
 - ButtonDisconnect
 - NxtDirectCommands1
 - BluetoothClient1
 - Clock1
- Properties:** A panel on the right showing the properties for the selected component (Screen1):
 - BackgroundColor: White
 - BackgroundImage: None...
 - Icon: None...
 - ScreenOrientation: Unspecified
 - Scrollable:
 - Title: Screen1
- Non-visible components:** A section at the bottom showing components that are not currently visible on the screen:
 - NxtDirectCommands1
 - BluetoothClient1
 - Clock1

©2010 Google - [About](#) - [Privacy](#) - [Terms](#)

Build: Tue Apr 19 10:31:49 2011 (1303234309) -- 20748564



元件

ListPicker

Basic→ListPicker

Label

Basic→Label

Button

Basic→Button

NxtDirectCommands

LEGO_MINDSTORMS_→NxtDirectCommands

BluetoothClient

Other stuff→BluetoothClient

Clock

Basic→Clock



Nxt各元件都要設定BluetoothClient

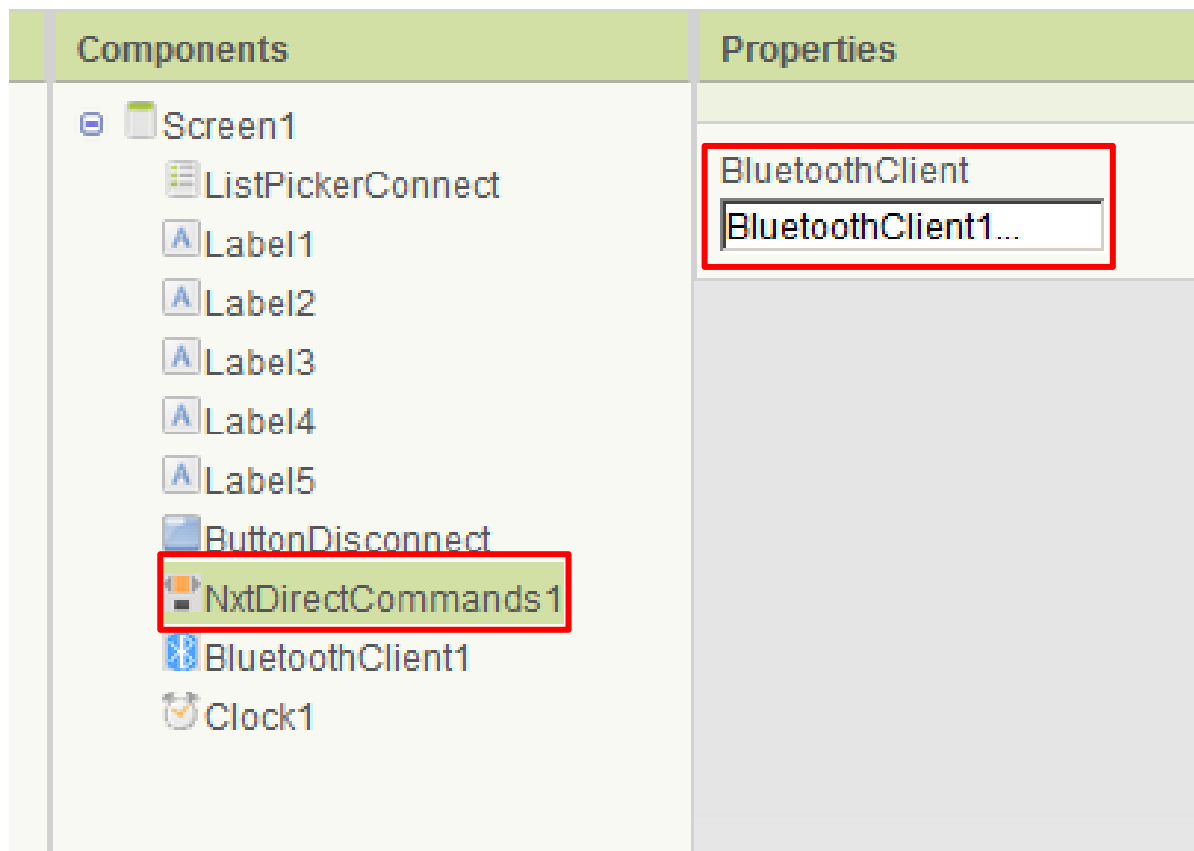

藍牙連線

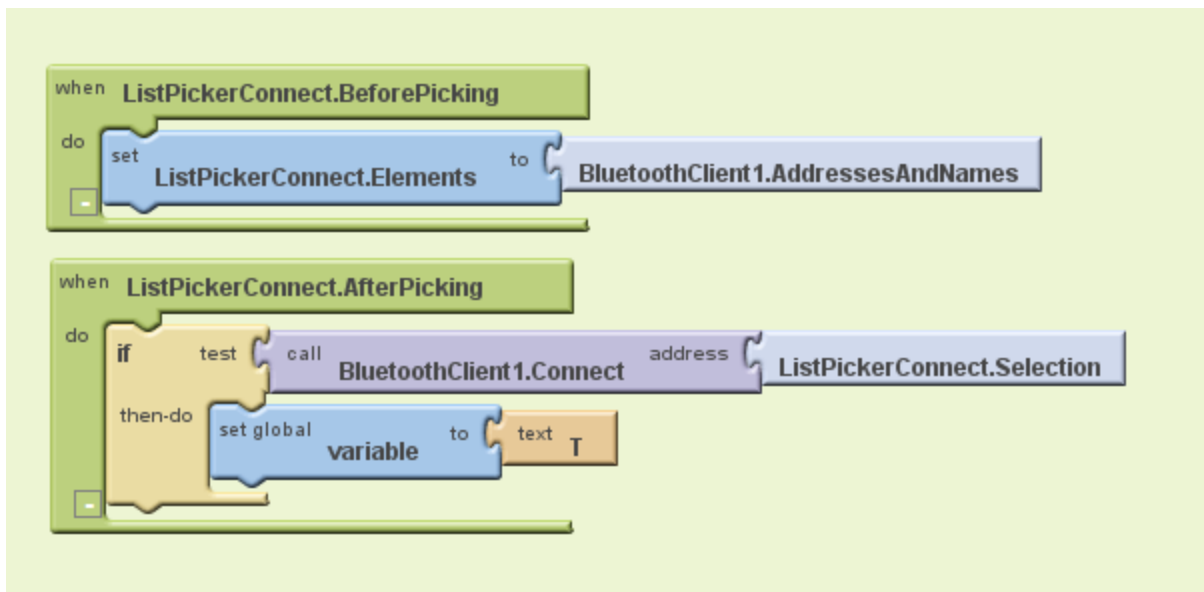

My Blocks

Listpicker → Listpicker.BeforePicking

Listpicker →

Listpicker .Elements

BluetoothClient → BluetoothClient
.AddressesAndNames

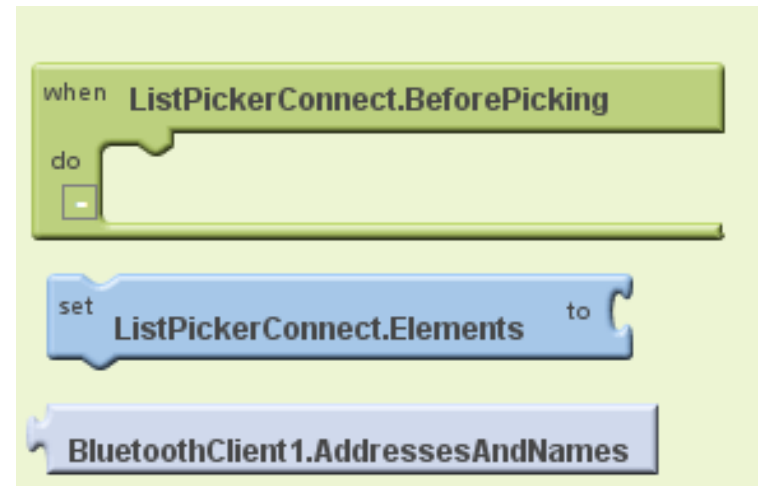

My Blocks

Listpicker→

Listpicker.AfterPicking

BluetoothClient→ BluetoothClient.Co

Listpicker→

Listpicker .Selection

Built-In

if

Control →if

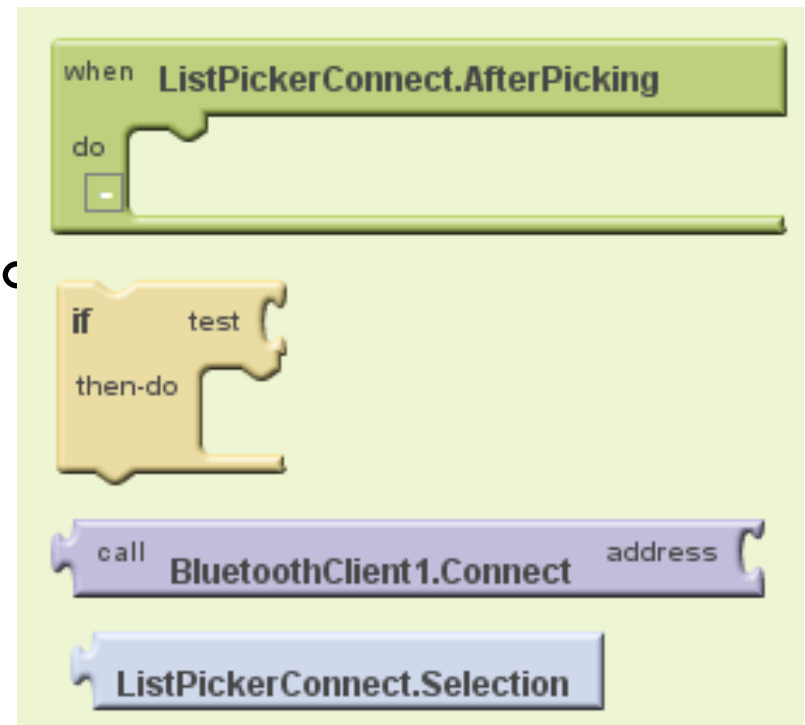

中斷藍牙連線

設置一個按鈕定義連線中斷

Button→

Button.Click

BluetoothClient→

BluetoothClient.Disconnect

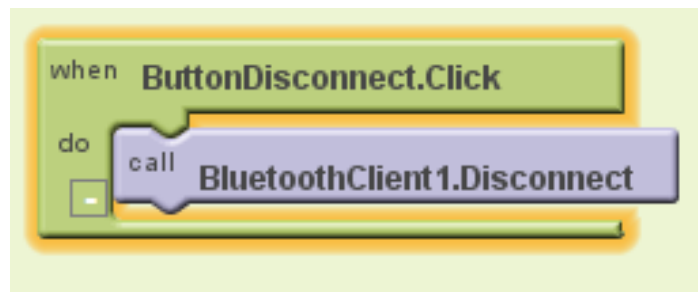

顯示NXT資訊



GetBatteryLevel 取得NXT電池電量



GetBrickName取得NXT機器人名稱



```
set Label3.Text to call NxtDirectCommands1.GetCurrentProgramName
```

GetCurrentProgramName
取得當前NXT執行程式

```
set Label4.Text to call NxtDirectCommands1.GetFirmwareVersion
```

GetFirmwareVersion取得韌體版本

```
set Label5.Text to ListPickerConnect.Selection
```

Selection取得藍牙資訊



資訊顯示完成圖



執行測試

執行測試(需要實體Android裝置)

※無法以VM做模擬執行

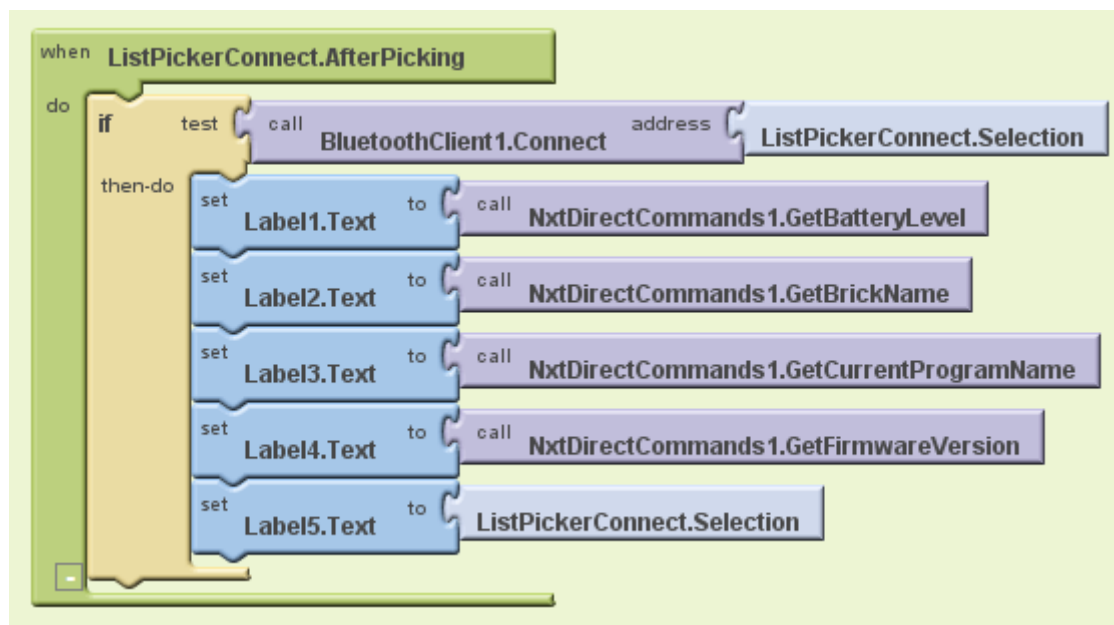

時間(Clock)

使用做連續讀取(100)

Clock → Clock.Timer

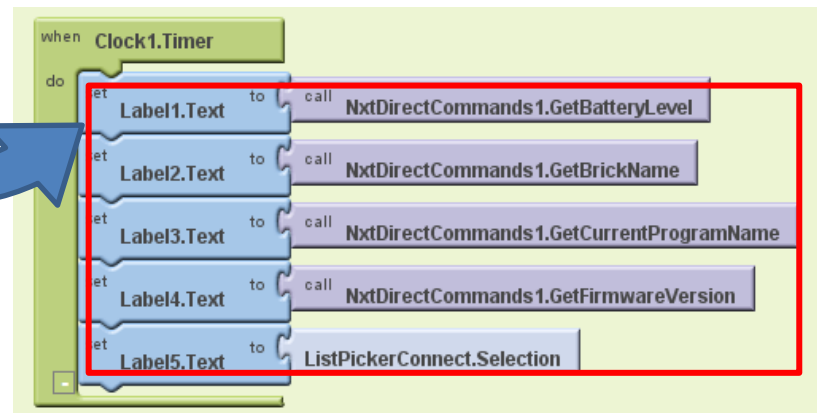
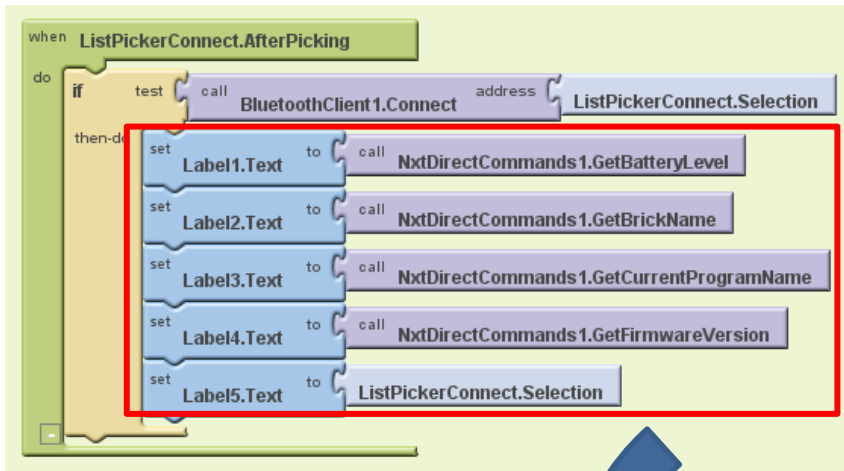

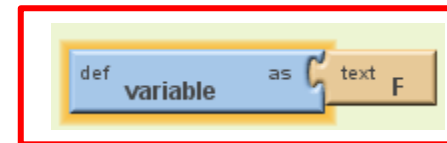
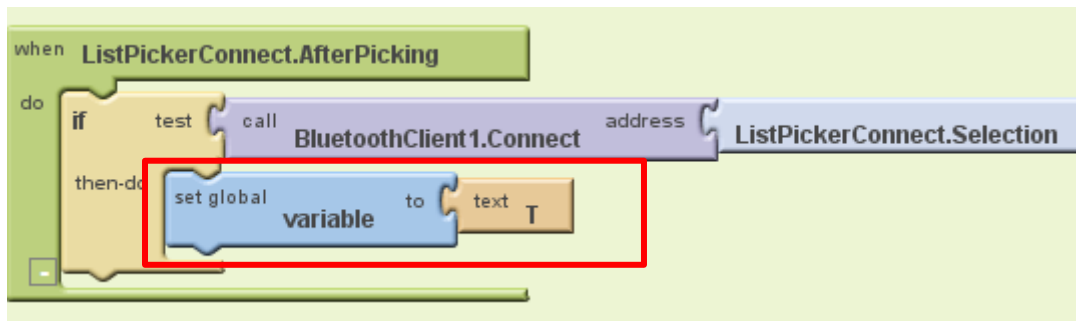

宣告一個變數
做為NXT資訊
擷取啟用判斷

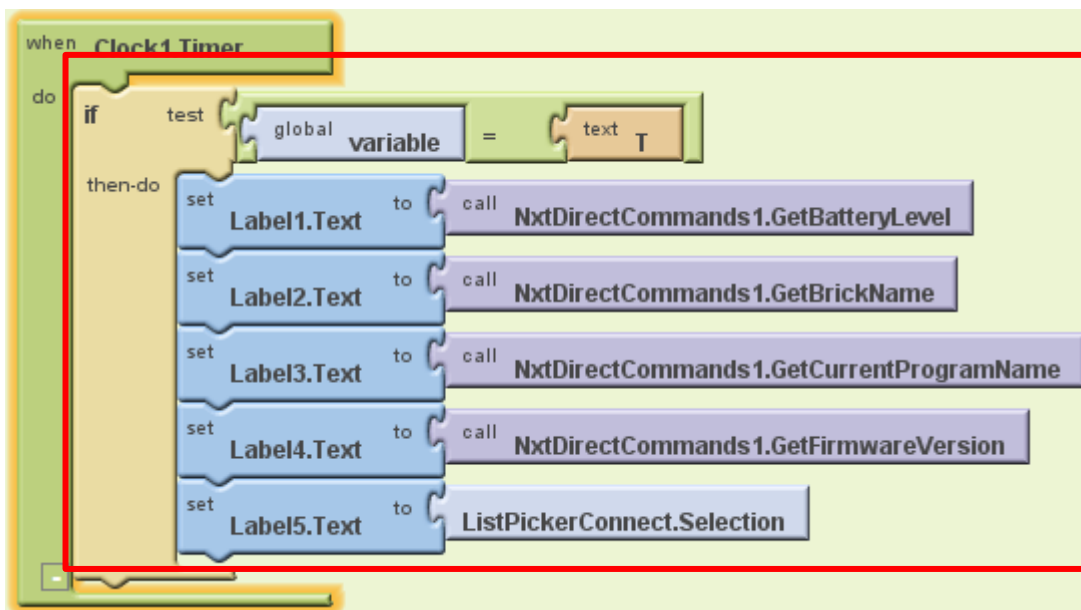

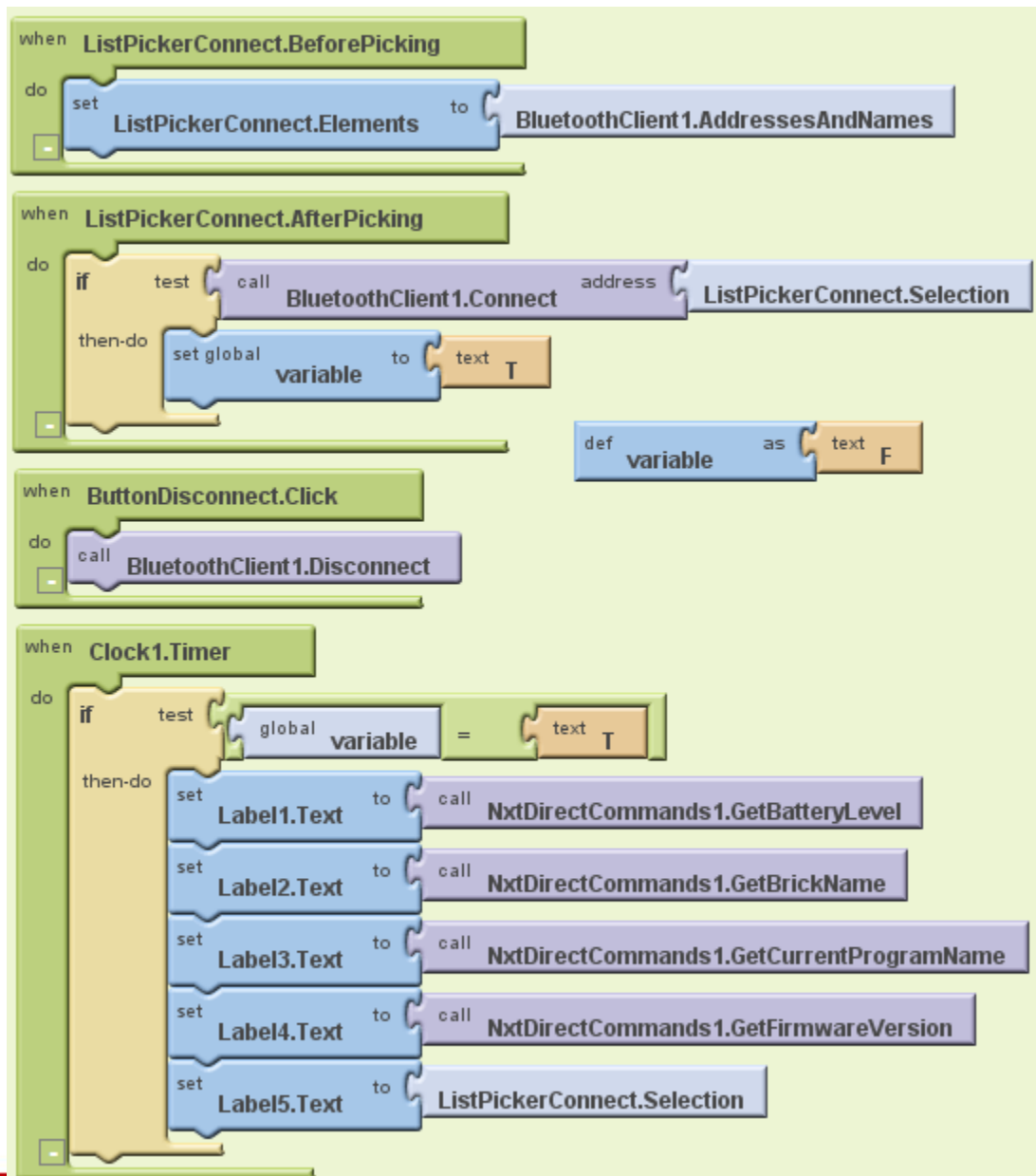

範例2：感應器面板

The screenshot displays the LEGO Mindstorms NXT Blocks Editor interface. The top bar includes 'LightSensorNXT', 'Save', 'Save As', 'Checkpoint', 'Blocks Editor is open', and 'Package for Phone'. The interface is divided into several panels:

- Palette:** Contains various UI components categorized by 'Basic', 'Media', 'Animation', 'Social', 'Sensors', 'Screen Arrangement', 'LEGO® MINDSTORMS®', 'Other stuff', 'Not ready for prime time', and 'Old stuff'. The 'Basic' category is expanded, showing items like Button, Canvas, CheckBox, Clock, Image, Label, ListPicker, PasswordTextBox, TextBox, and TinyDB.
- Viewer:** Shows a preview of the 'Screen1' component. It includes a status bar with '5:09 PM' and a 'Display Invisible Components in Viewer' checkbox. The screen content includes labels for '連芽裝置連線', '光感值:', '分貝值:', '按鈕:', '距離值:', and '藍芽連線中斷'. Below the viewer is a 'Non-visible components' list containing: NxtLightSensor1, BluetoothClient1, Clock1, NxtSoundSensor1, NxtTouchSensor1, and NxtUltrasonicSensor1.
- Components:** A tree view showing the hierarchy of components on the screen, including Screen1, ListPicker1, HorizontalArrangement1, Label1, Label3LS, HorizontalArrangement3, Label4, Label2SS, HorizontalArrangement4, Label6, Label1TS, HorizontalArrangement5, Label8, Label4US, Button2, Label3, NxtLightSensor1, BluetoothClient1, Clock1, and NxtSoundSensor1. 'Rename...' and 'Delete...' buttons are visible at the bottom.
- Properties:** Shows the properties for the selected 'Screen1' component, including BackgroundColor (White), BackgroundImage (None...), Icon (None...), ScreenOrientation (Unspecified), Scrollable (checked), and Title (Screen1).

©2010 Google - [About](#) - [Privacy](#) - [Terms](#) Build: Tue Apr 19 10:31:49 2011 (1303234309) -- 20748564



NXT感應器元件

NxtLightSensor

NxtSoundSensor

NxtTouchSensor

NxtUltrasonicSensor



NXT感應器Port設定

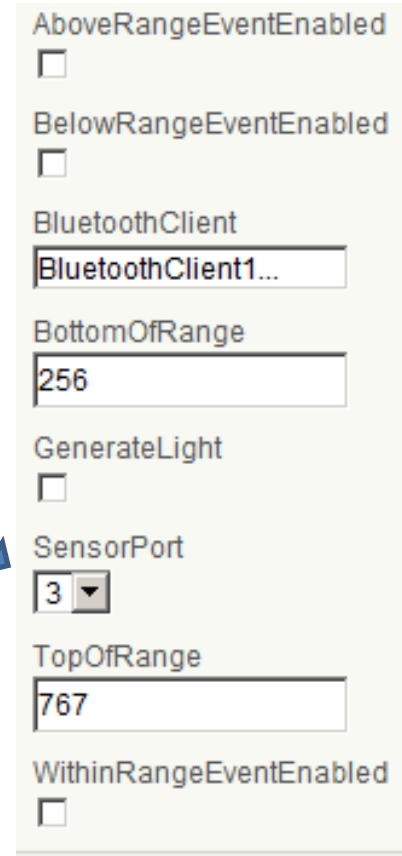
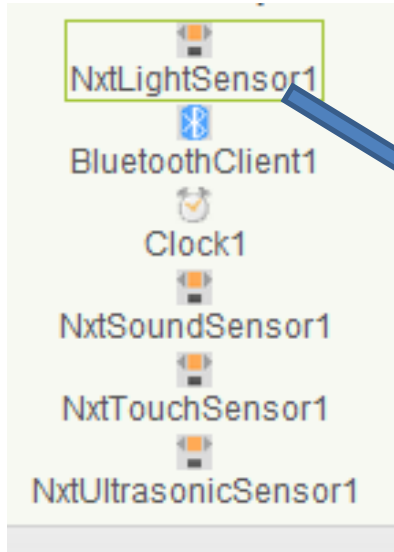

NxtLightSensor

GetLightLevel (0~100)

NxtSoundSensor

GetSoundLevel (0~100)

NxtTouchSensor

IsPressed (true / false)

NxtUltrasonicSensor

GetDistance (0~255)



顯示NXT感應器數值

光感值

分貝值

按鈕判斷

距離值(cm)

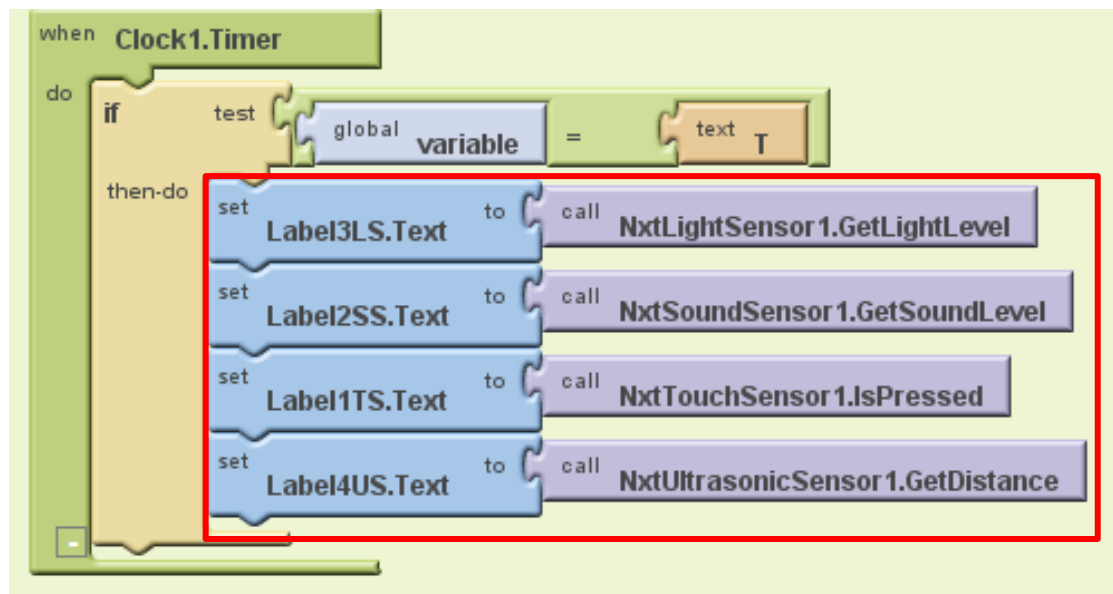

```
when ListPicker1.BeforePicking
do
  set ListPicker1.Elements to BluetoothClient1.AddressesAndNames

when ListPicker1.AfterPicking
do
  if test call BluetoothClient1.Connect address ListPicker1.Selection
  then-do
    set global variable to text T

when Button2.Click
do
  call BluetoothClient1.Disconnect

when Clock1.Timer
do
  if test global variable = ▾ text T
  then-do
    set Label3LS.Text to call NxtLightSensor1.GetLightLevel
    set Label2SS.Text to call NxtSoundSensor1.GetSoundLevel
    set Label1TS.Text to call NxtTouchSensor1.IsPressed
    set Label4US.Text to call NxtUltrasonicSensor1.GetDistance
```

def variable as text F

```
when ListPicker1.BeforePicking
do
  set ListPicker1.Elements to BluetoothClient1.AddressesAndNames
```

```
when ListPicker1.AfterPicking
do
  if test call BluetoothClient1.Connect address ListPicker1.Selection
  then-do
    set global variable to text T
```

```
when Button2.Click
do
  call BluetoothClient1.Disconnect
```

```
when Clock1.Timer
do
  if test global variable = ▾ text T
  then-do
    set Label3LS.Text to call NxtLightSensor1.GetLightLevel
    set Label2SS.Text to call NxtSoundSensor1.GetSoundLevel
    set Label1TS.Text to call NxtTouchSensor1.IsPressed
    set Label4US.Text to call NxtUltrasonicSensor1.GetDistance
```



範例3：按鈕控制



Non-visible components

BluetoothClient NxtDriveB NxtDriveC NxtDirectCommands SoundBeep



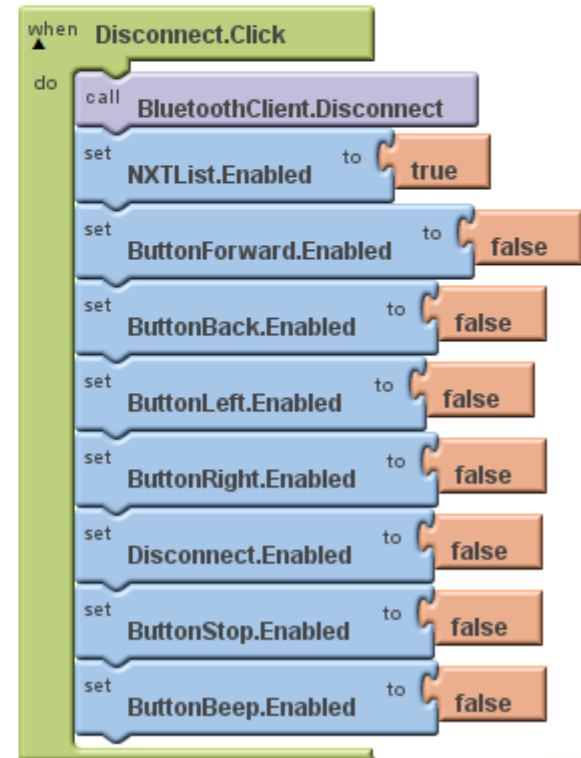
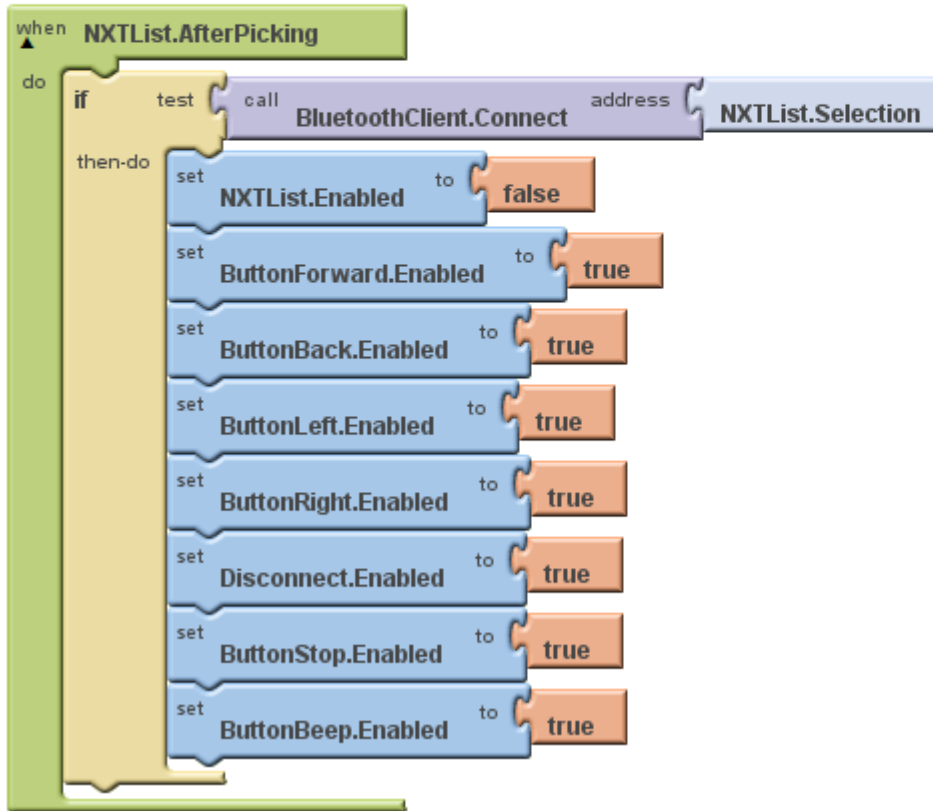
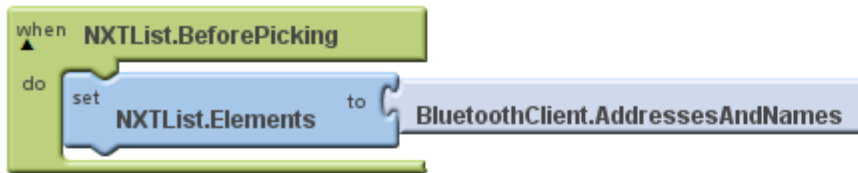

```
when ButtonForward.Click
do
  call NxtDriveB.MoveForwardIndefinitely power number 100
  call NxtDriveC.MoveForwardIndefinitely power number 100
```

```
when ButtonBack.Click
do
  call NxtDriveB.MoveBackwardIndefinitely power number 100
  call NxtDriveC.MoveBackwardIndefinitely power number 100
```

```
when ButtonStop.Click
do
  call NxtDriveB.Stop
  call NxtDriveC.Stop
```

```
when ButtonLeft.Click
do
  call NxtDriveB.MoveForwardIndefinitely power number 100
  call NxtDriveC.MoveForwardIndefinitely power number 50
```

```
when ButtonRight.Click
do
  call NxtDriveB.MoveForwardIndefinitely power number 50
  call NxtDriveC.MoveForwardIndefinitely power number 100
```

```
when ButtonBeep.Click
do
  call NxtDirectCommands.PlayTone frequencyHz number 880
  durationMs number 300
```



範例4：翻轉控制

利用手機內的姿態感測器來控制機器人



藍牙連線前後的設定(同前)

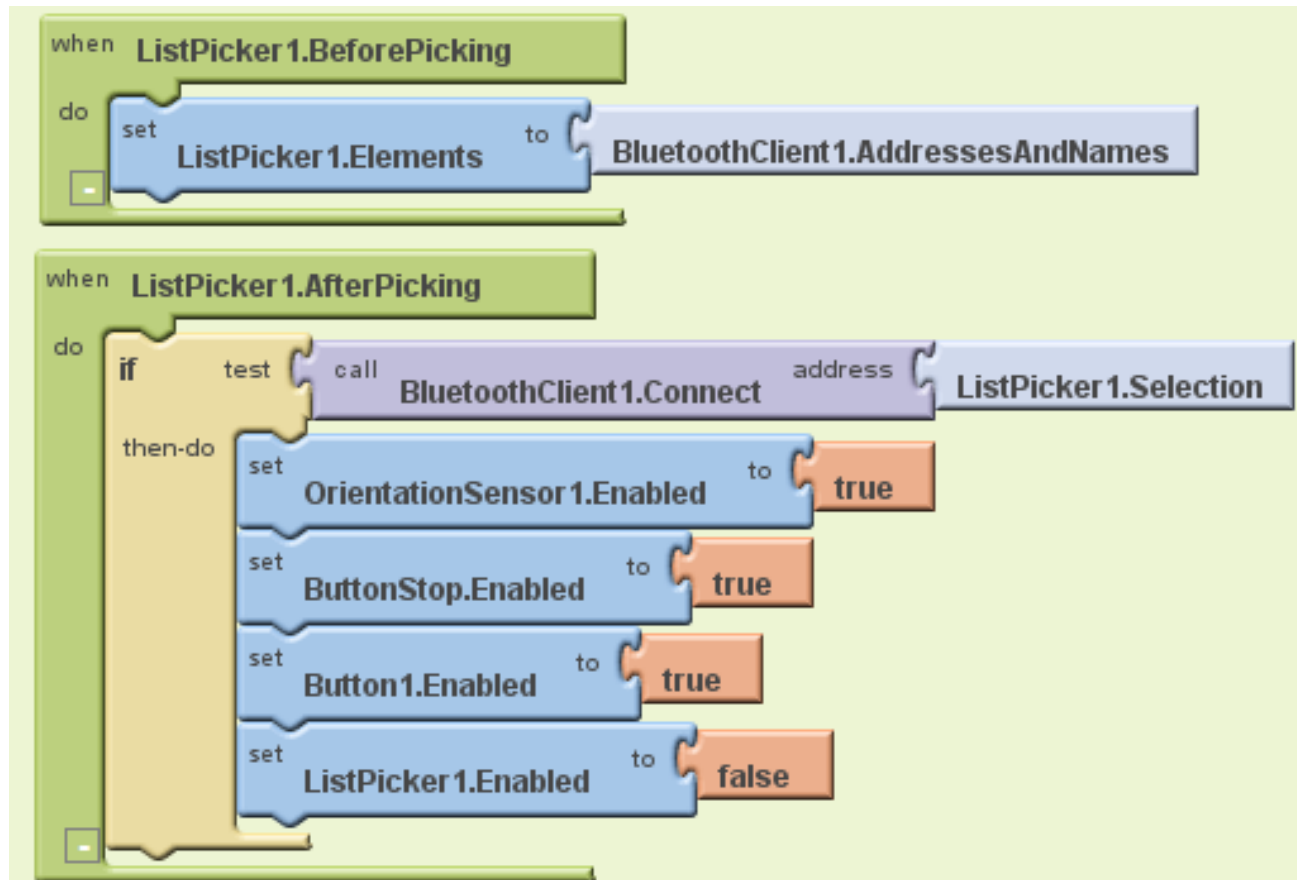

中斷藍牙連線

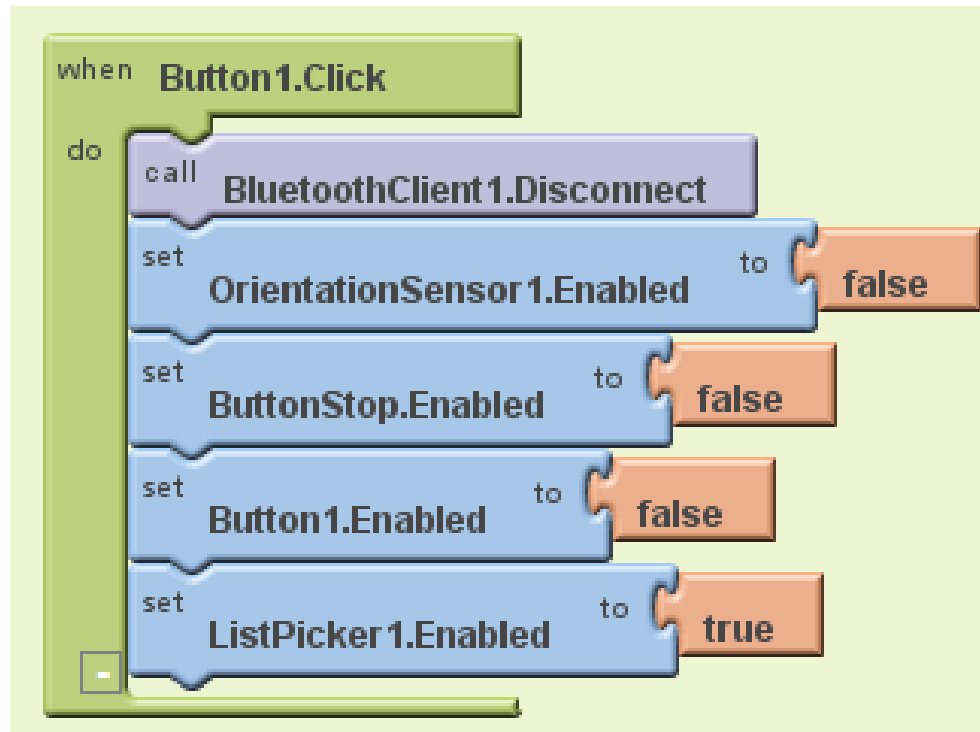

設定變數

設定變數接收手機
X-Y數值做運算

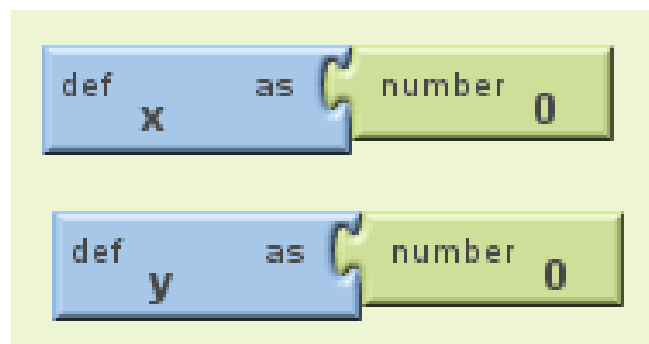

```

when OrientationSensor1.OrientationChanged
  yaw name yaw
  pitch name pitch
  roll name roll

do
  set LabelPitch.Text to
    text Pitch: join value pitch x number 2
  set LabelRoll.Text to
    text Roll: join value roll x number -2
  set global x to
    call atan2 x value pitch
    value roll x number -1 - number 45
  set global y to
    call sqrt value roll x value roll + value pitch x value pitch x number 8
  call NxtDriveB.MoveForwardIndefinitely power
    call cos degrees global x x global y
  call NxtDriveC.MoveForwardIndefinitely power
    call sin degrees global x x global y
  set LabelLeftMotor.Text to
    text LeftMotorPower join call cos degrees global x x global y
  set LabelRightMotor.Text to
    text RightMotorPower join call sin degrees global x x global y

```



停止

停止B-C馬達。

